



US 20060022587A1

(19) **United States**

(12) **Patent Application Publication**  
**Jeong et al.**

(10) **Pub. No.: US 2006/0022587 A1**

(43) **Pub. Date: Feb. 2, 2006**

(54) **ELECTROLUMINESCENT DISPLAY DEVICE  
AND METHOD OF FABRICATING THE  
SAME**

**Publication Classification**

(51) **Int. Cl.**  
**H05B 33/00** (2006.01)  
(52) **U.S. Cl.** ..... **313/504**

(76) **Inventors: Chang-Yong Jeong, Suwon-si (KR);  
Tae-Wook Kang, Seongnam-si (KR);  
Chang-Soo Kim, Suwon-si (KR);  
Yu-Sung Cho, Yeongam-gun (KR)**

(57) **ABSTRACT**

An electroluminescent (EL) display device and a method of fabricating the same are provided. The device includes a substrate; a plurality of pixel electrodes disposed on the substrate; a pixel defining layer disposed on the pixel electrodes and having an opening part exposing a predetermined part of each of the pixel electrodes; and at least one barrier layer comprised in and/or on the pixel defining layer. In this device, the pixel defining layer includes at least one barrier layer in order to reduce the amount of outgas from the pixel defining layer and prevent degradation of an emission portion due to the outgas. Also, the pixel defining layer is formed to a sufficiently small thickness to facilitate a subsequent process using a laser induced thermal imaging (LITI) process.

Correspondence Address:  
**MCGUIREWOODS, LLP**  
**1750 TYSONS BLVD**  
**SUITE 1800**  
**MCLEAN, VA 22102 (US)**

(21) **Appl. No.: 11/143,952**

(22) **Filed: Jun. 3, 2005**

(30) **Foreign Application Priority Data**

Jun. 4, 2004 (KR) ..... 10-2004-0041066  
Jun. 29, 2004 (KR) ..... 10-2004-0049709

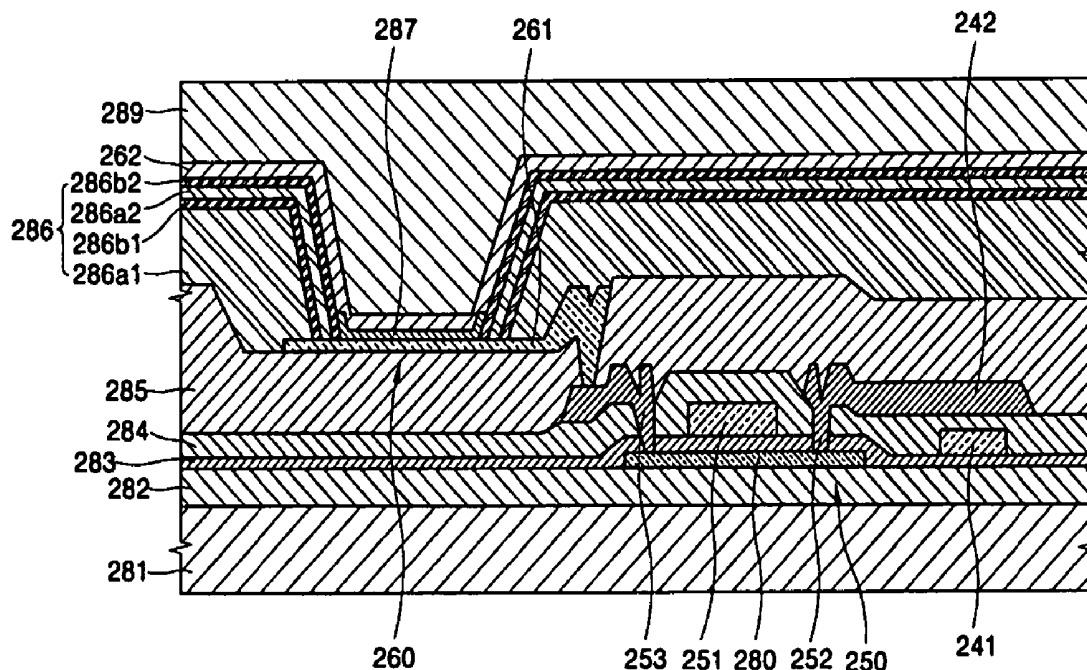

FIG. 1  
(PRIOR ART)

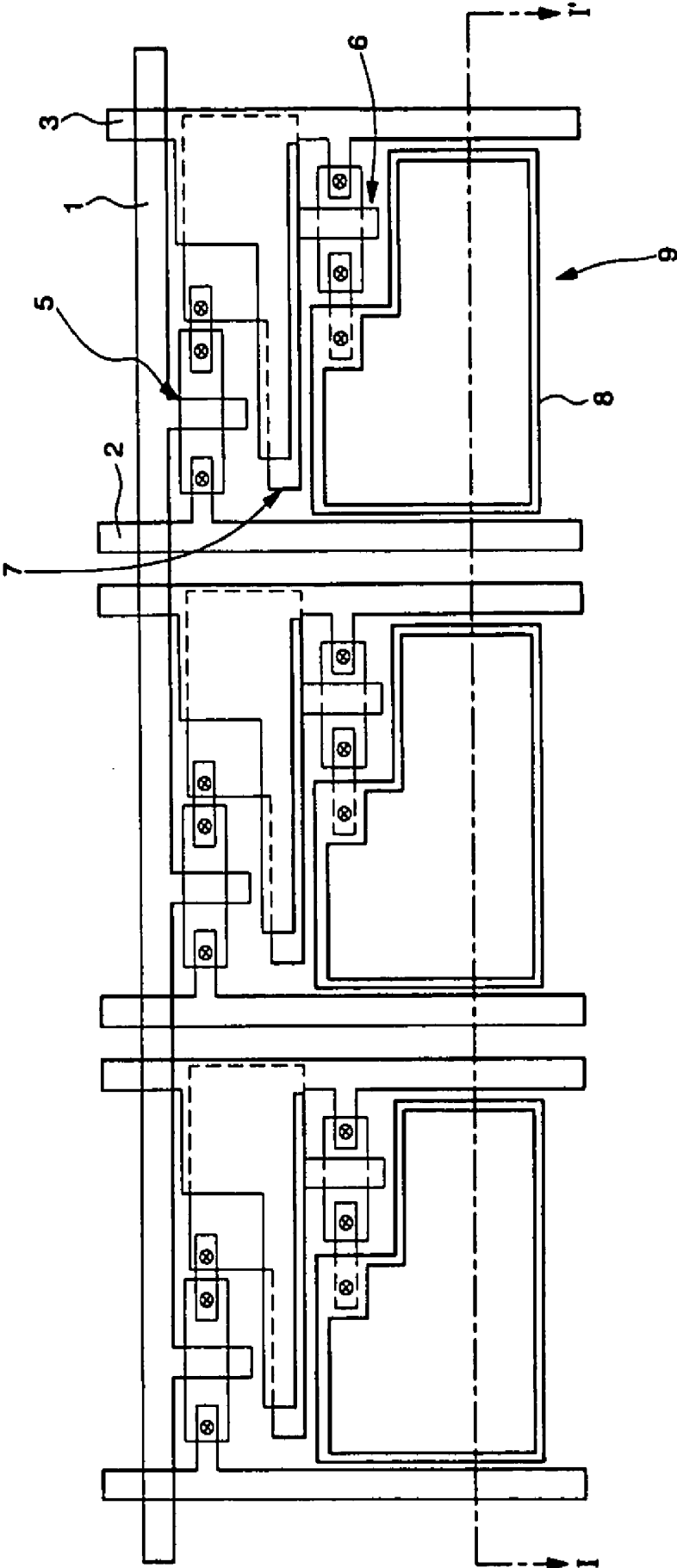

FIG. 2  
(PRIOR ART)

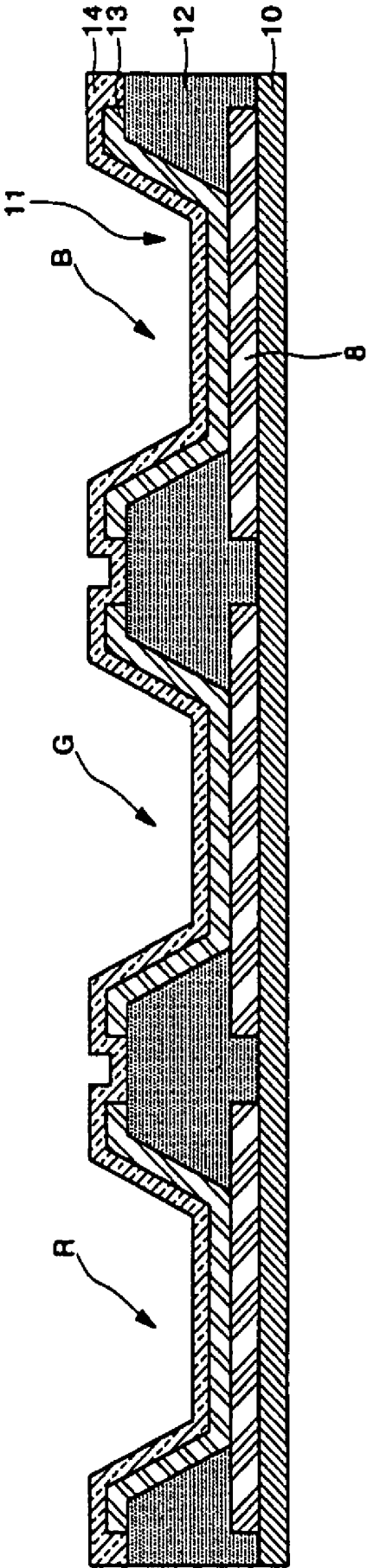

FIG. 3A

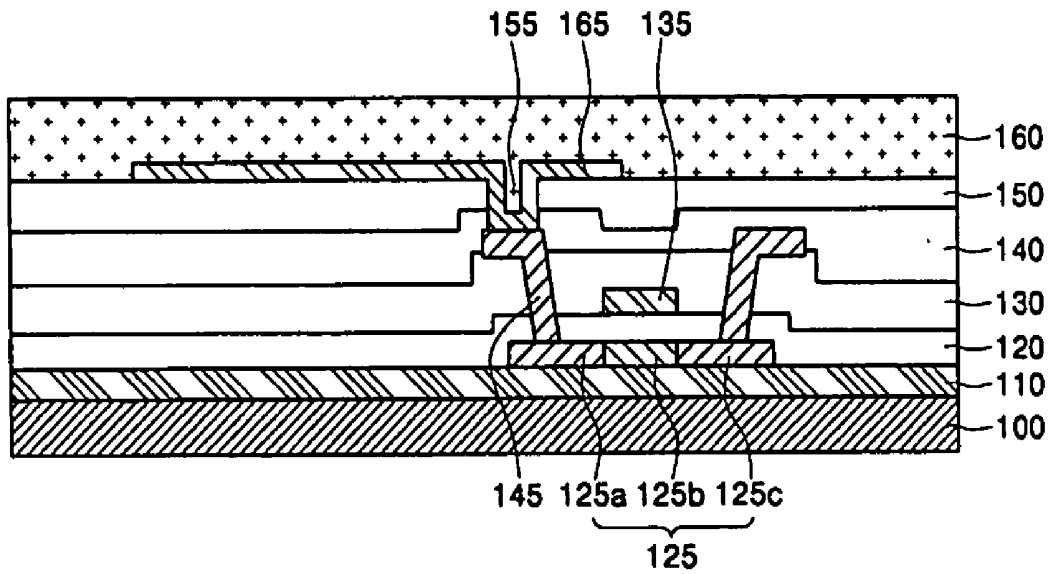

FIG. 3B

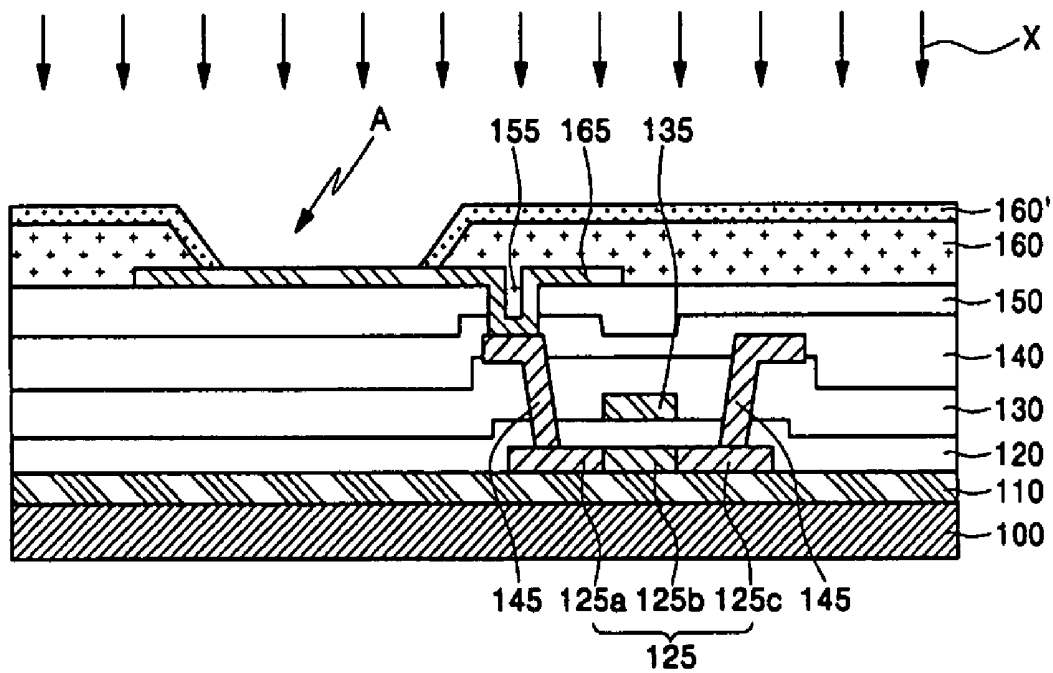

FIG. 3C

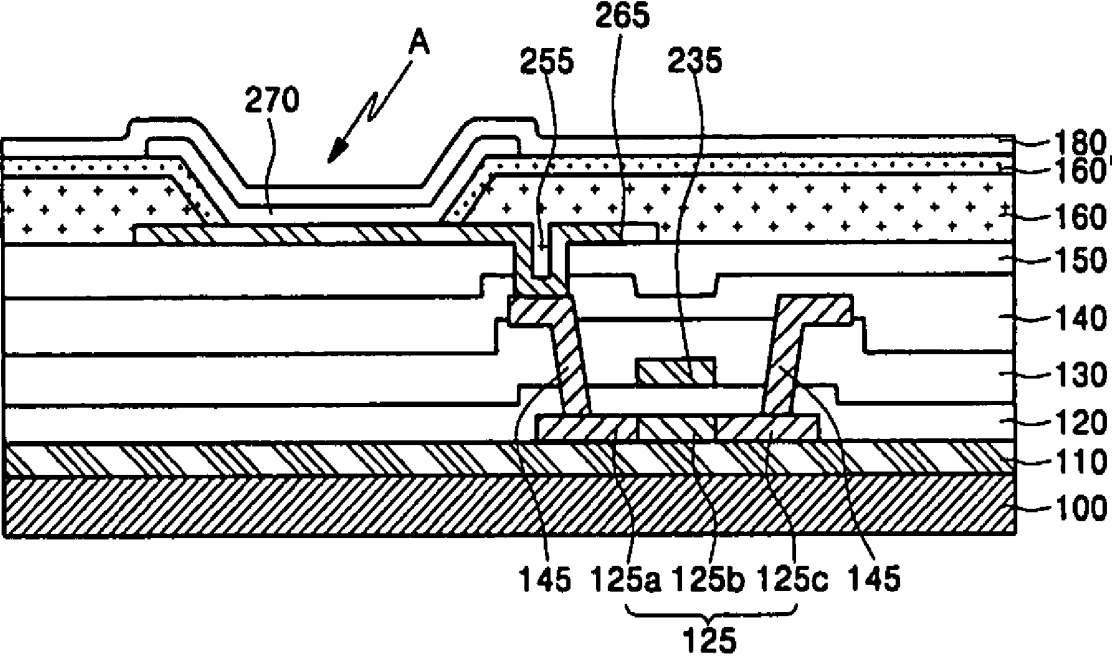

FIG. 4

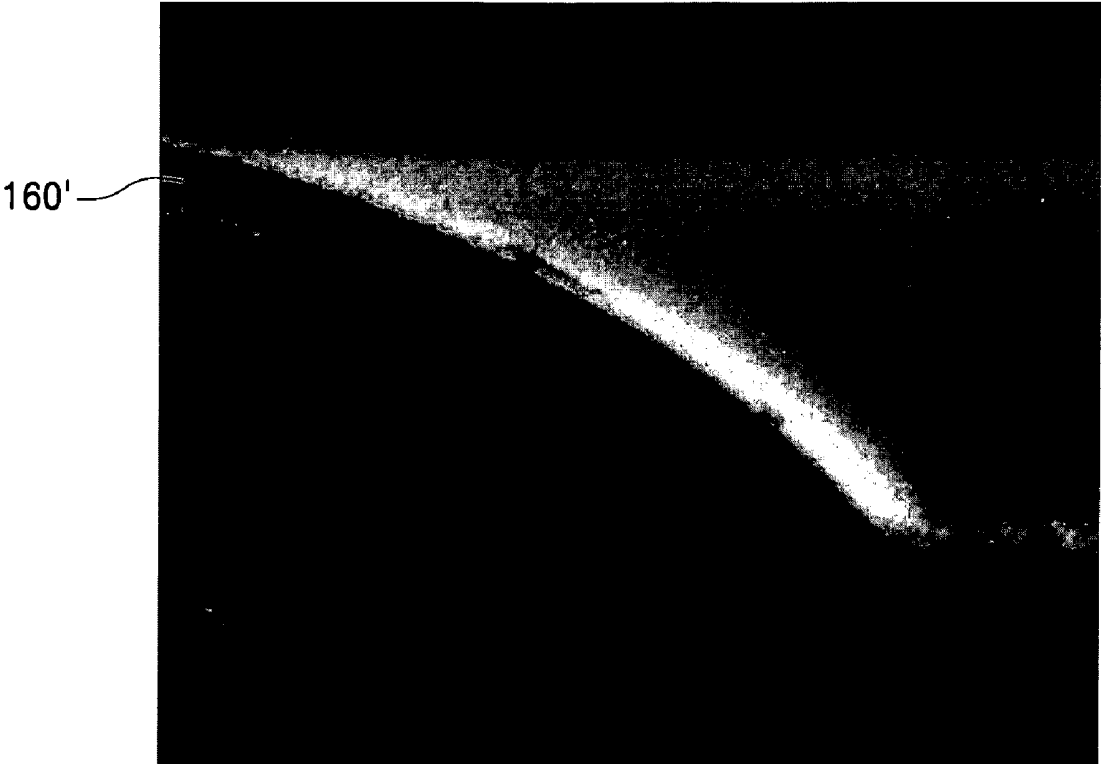

FIG. 5

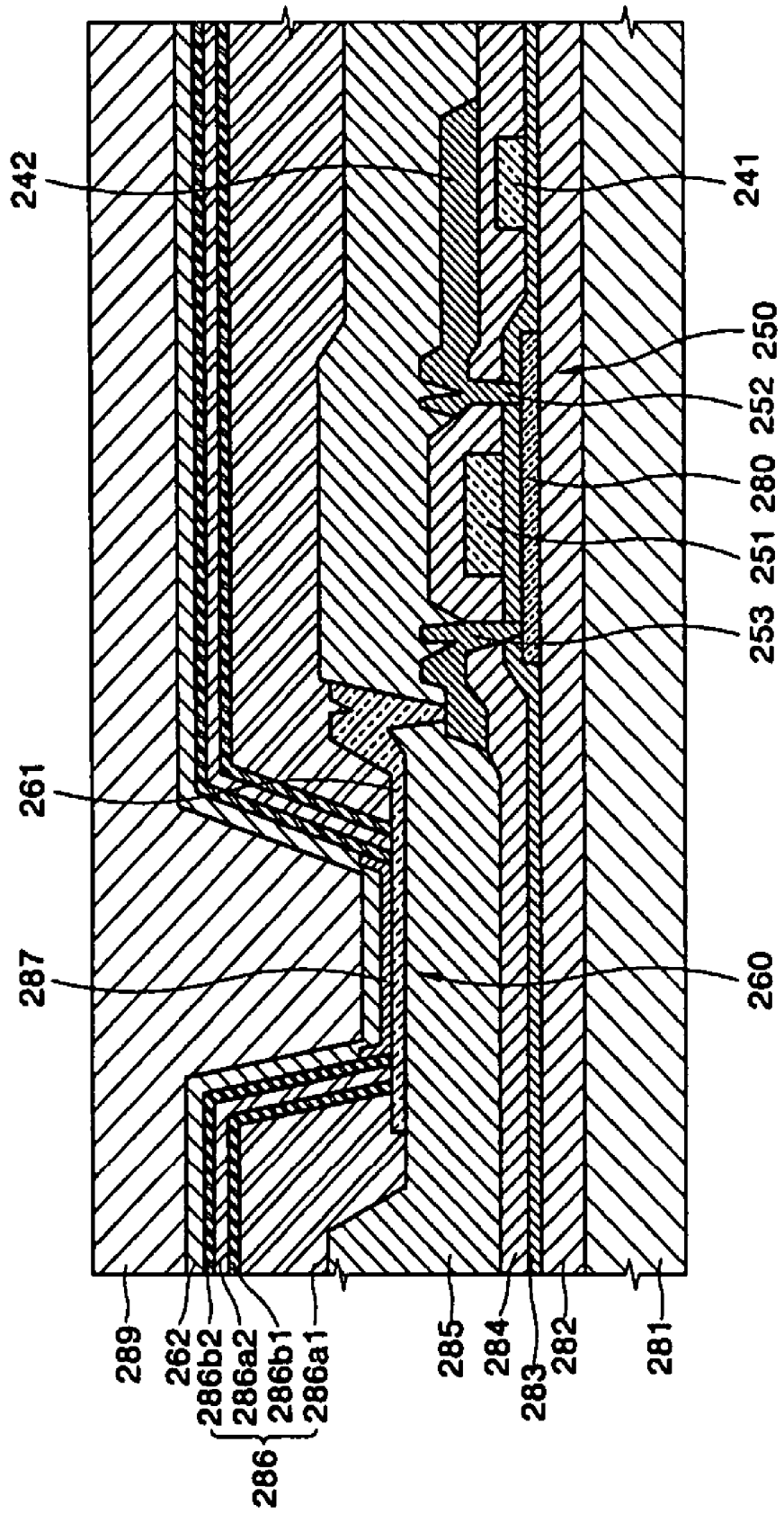



FIG. 7

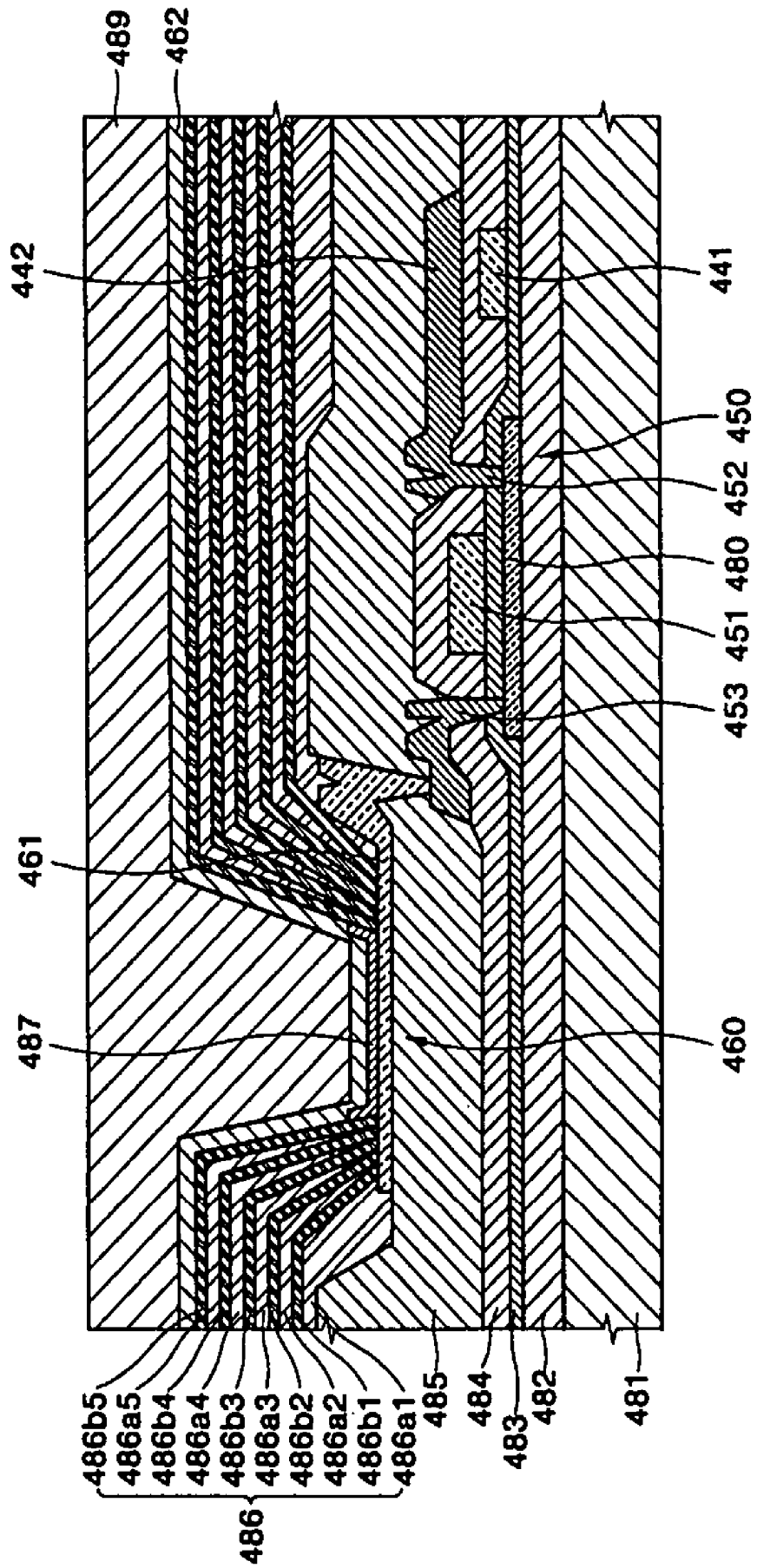

FIG. 8

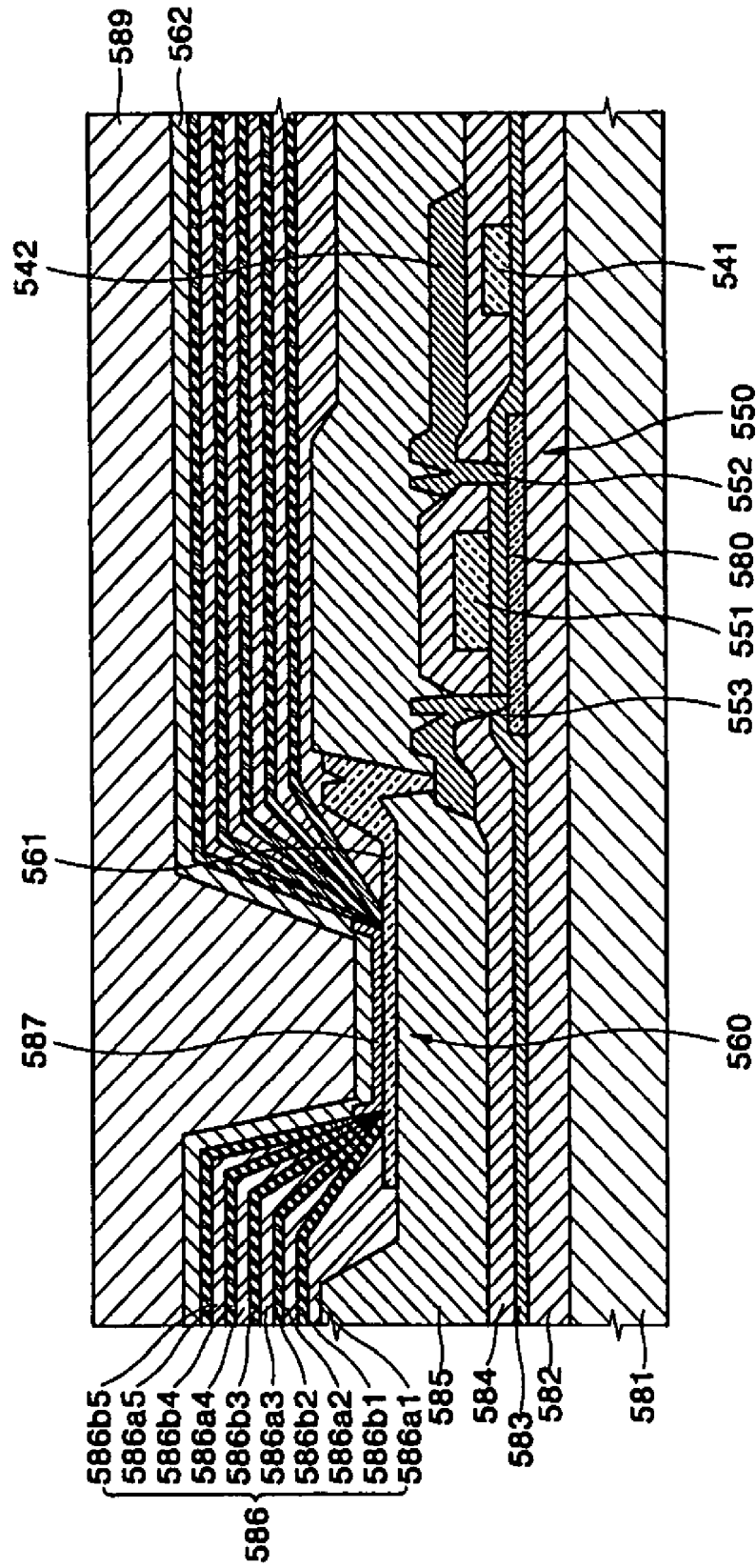

FIG. 9

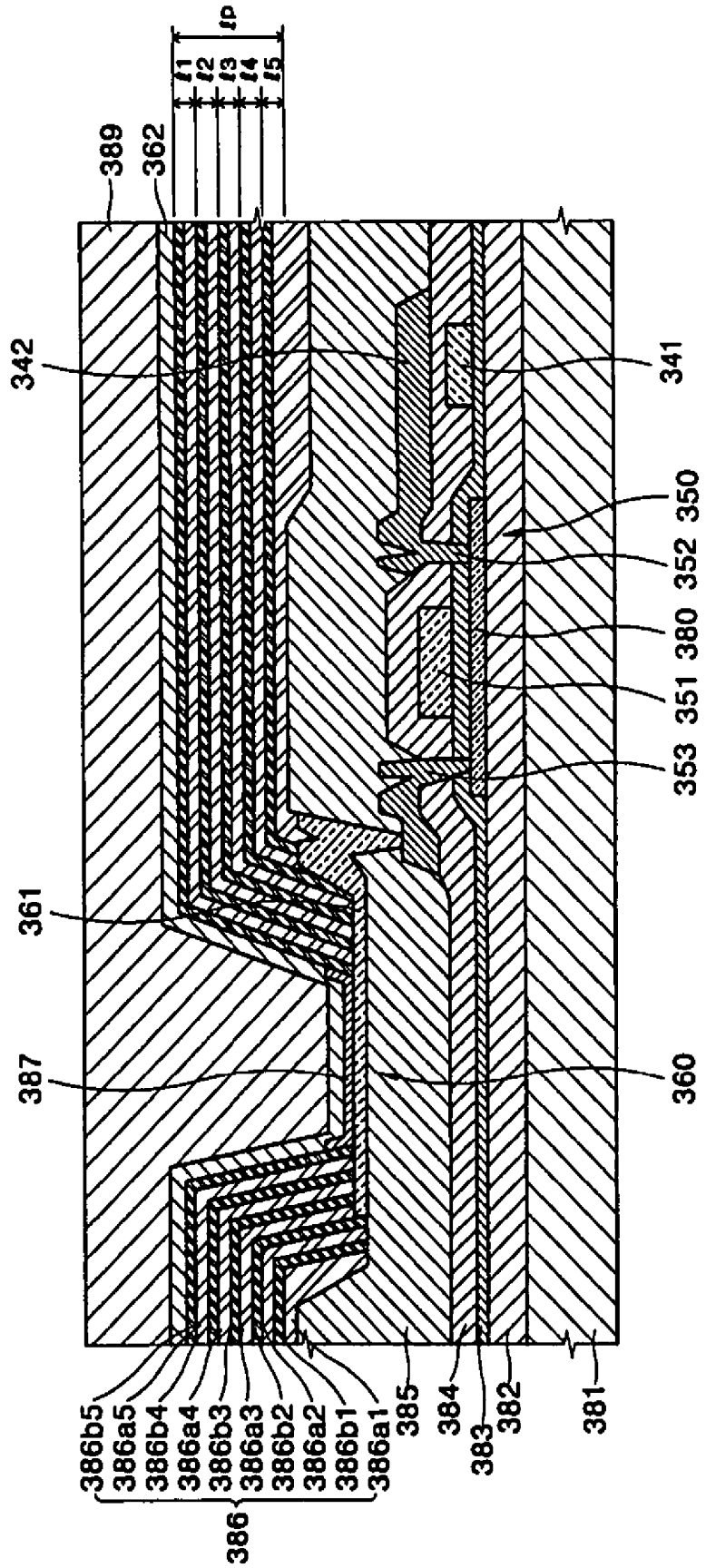

FIG. 10

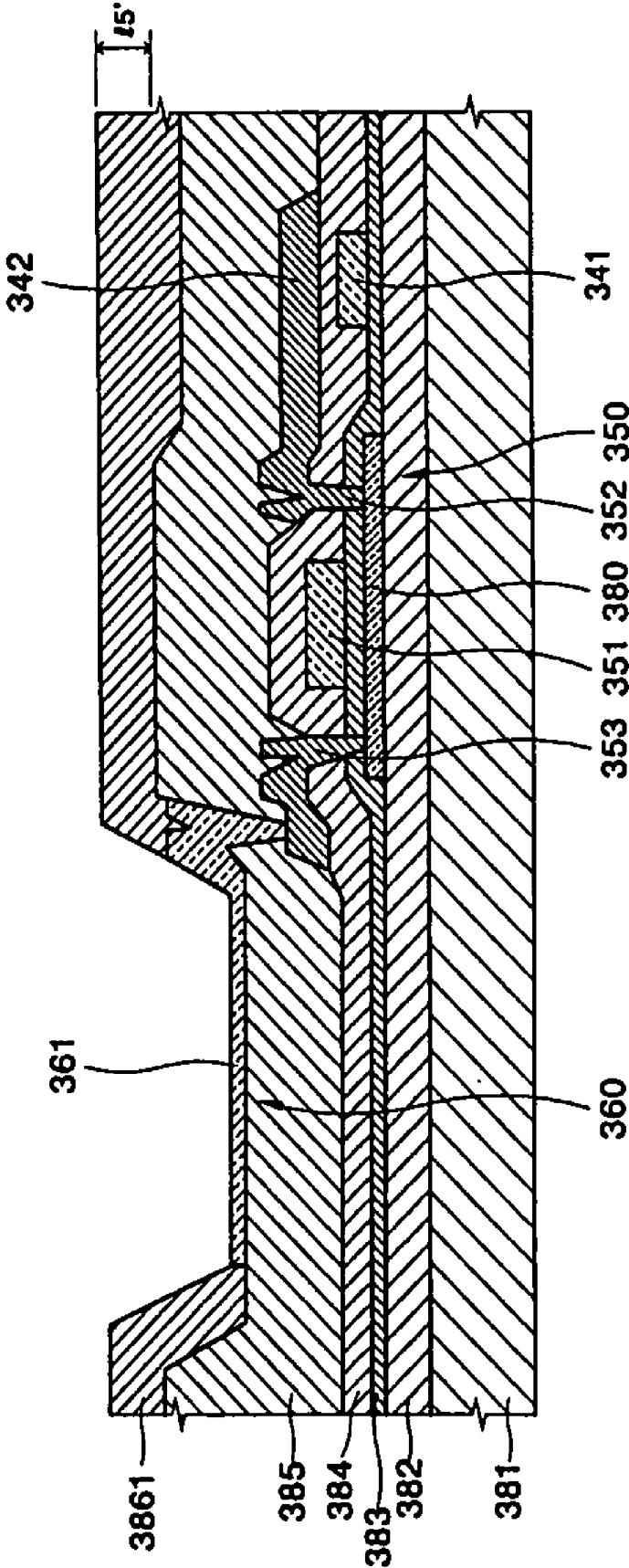

FIG. 11

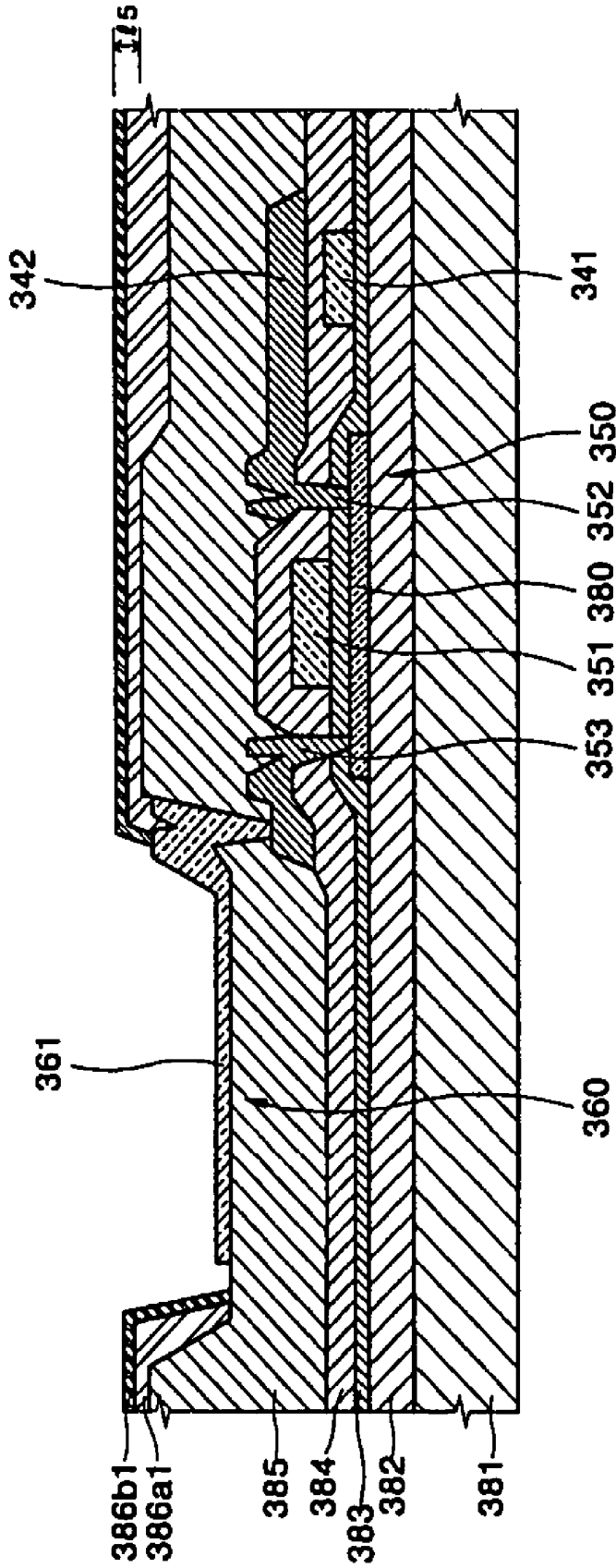

FIG. 12

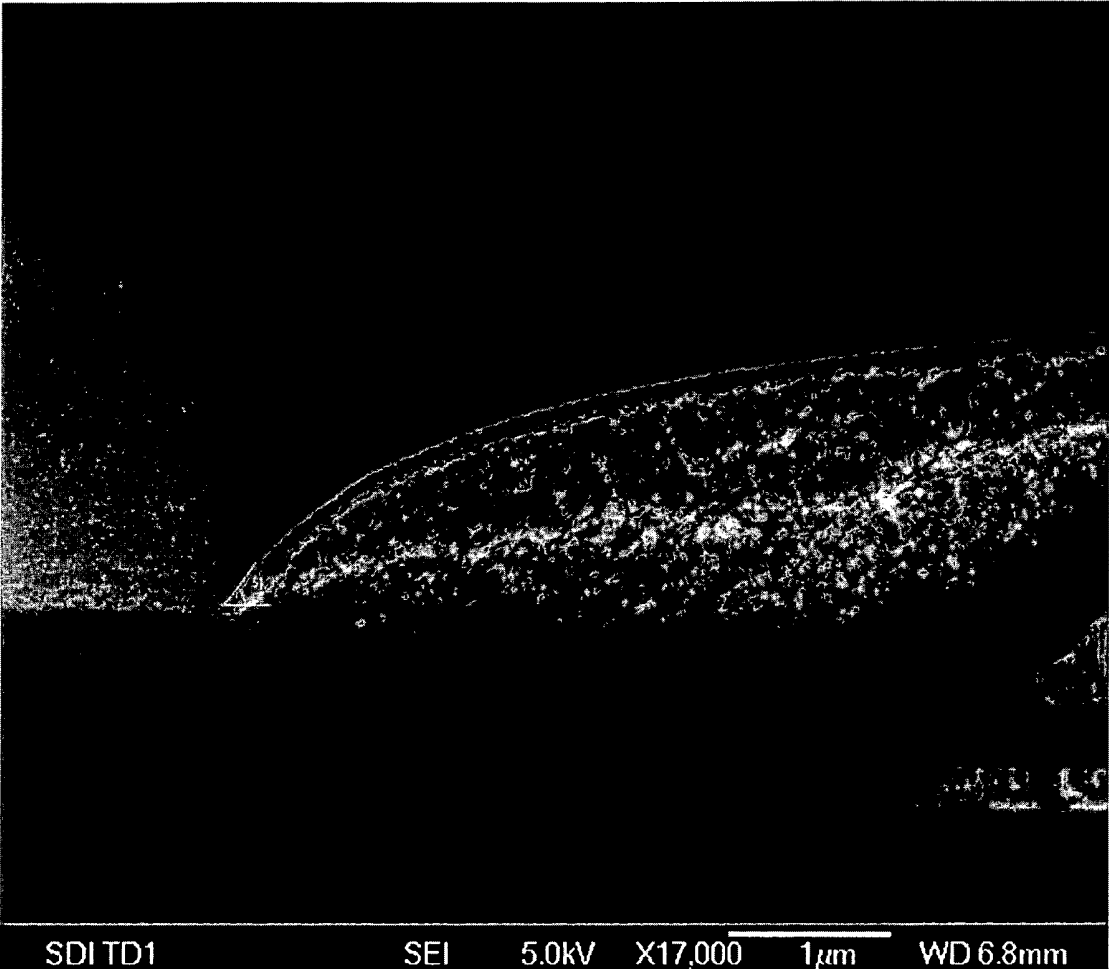

FIG. 13

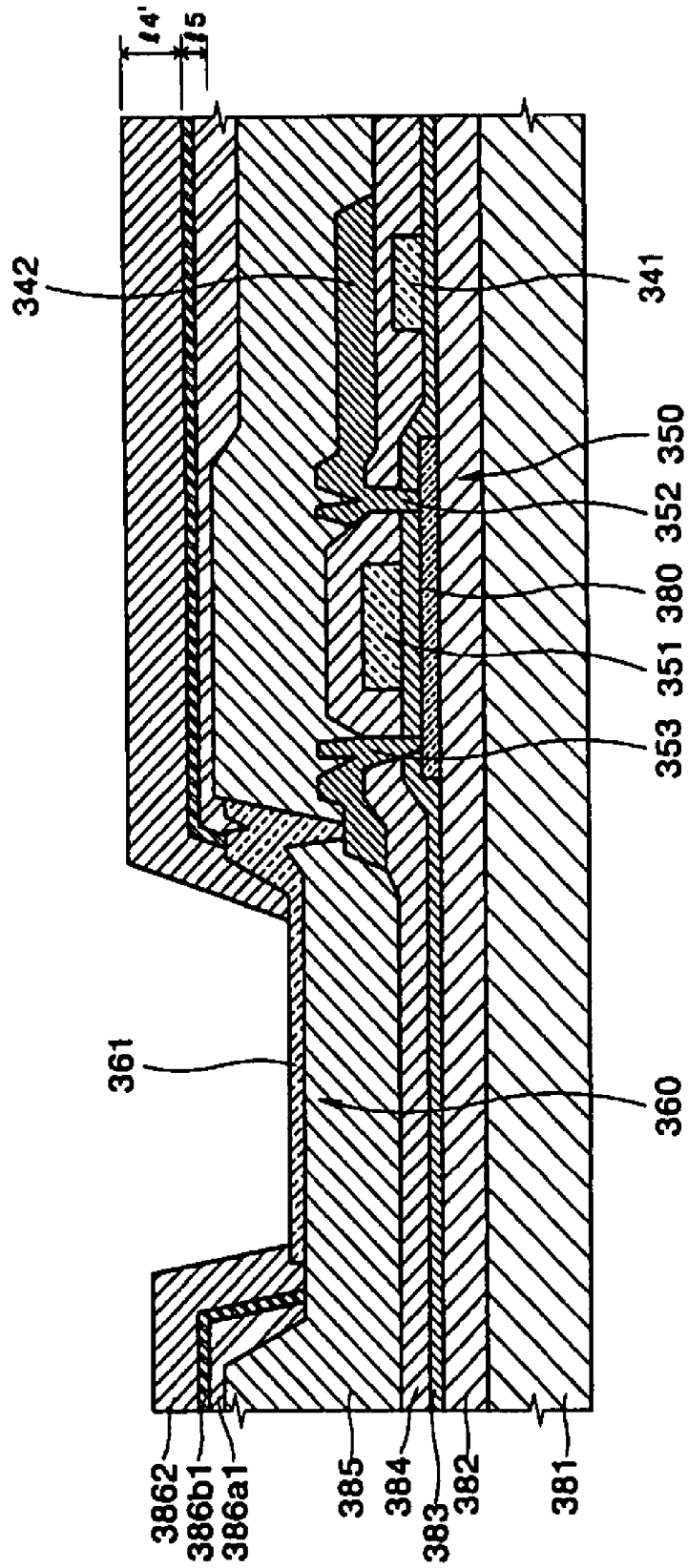

FIG. 14

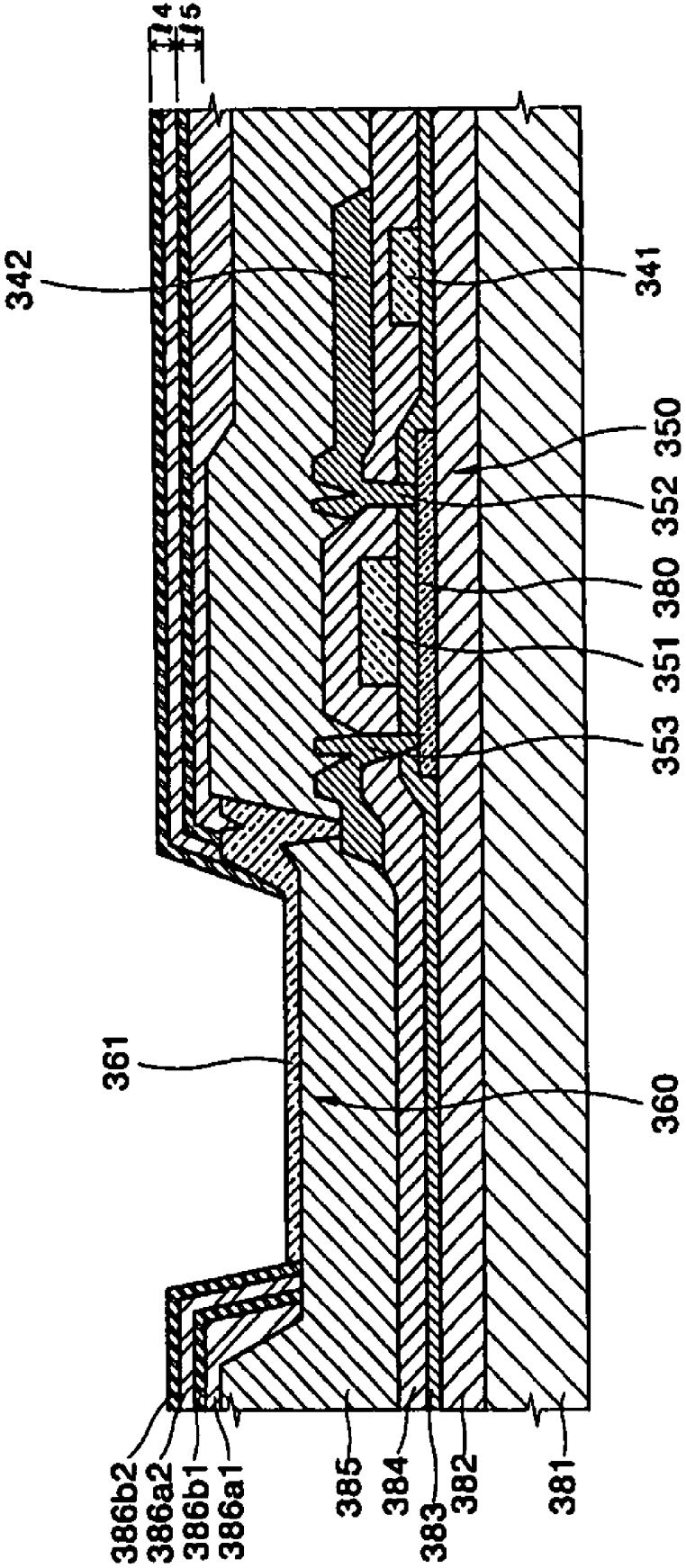

FIG. 15

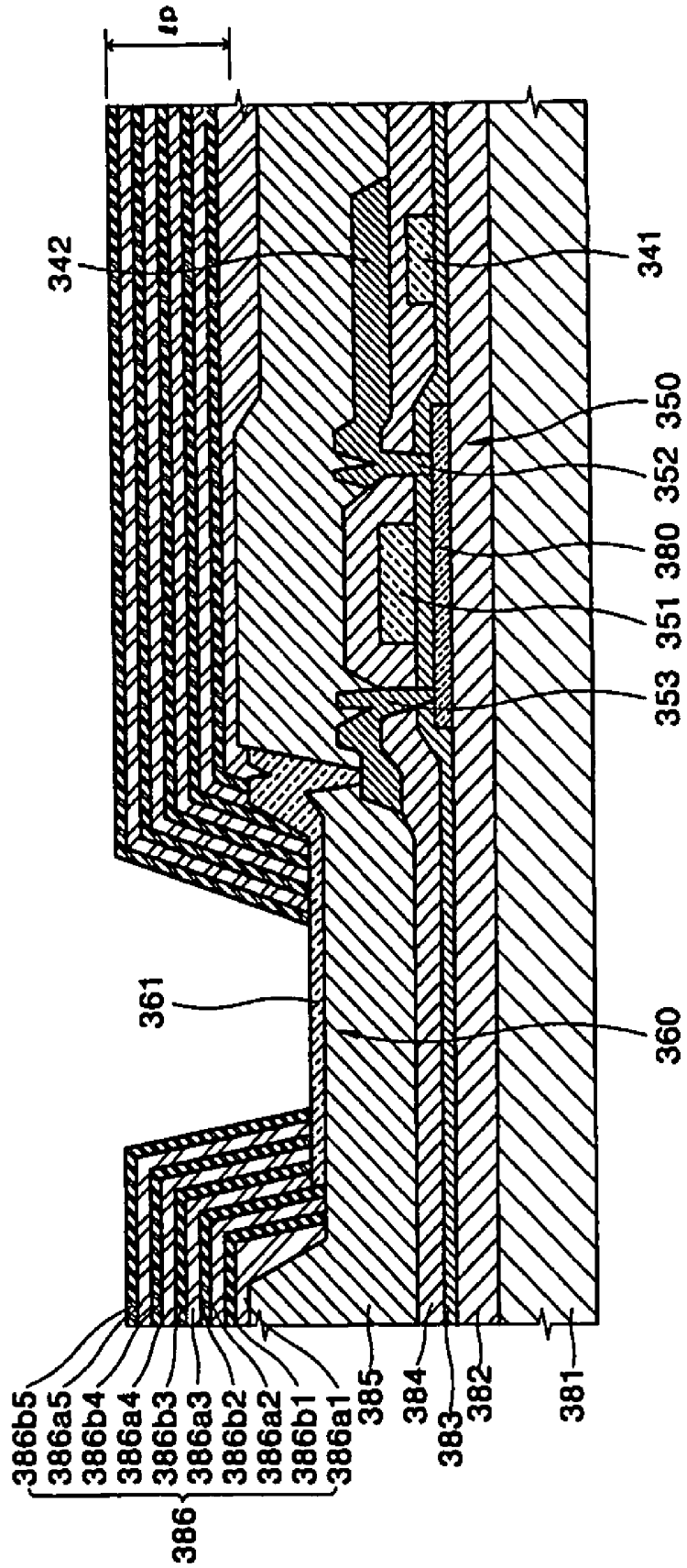

FIG. 16

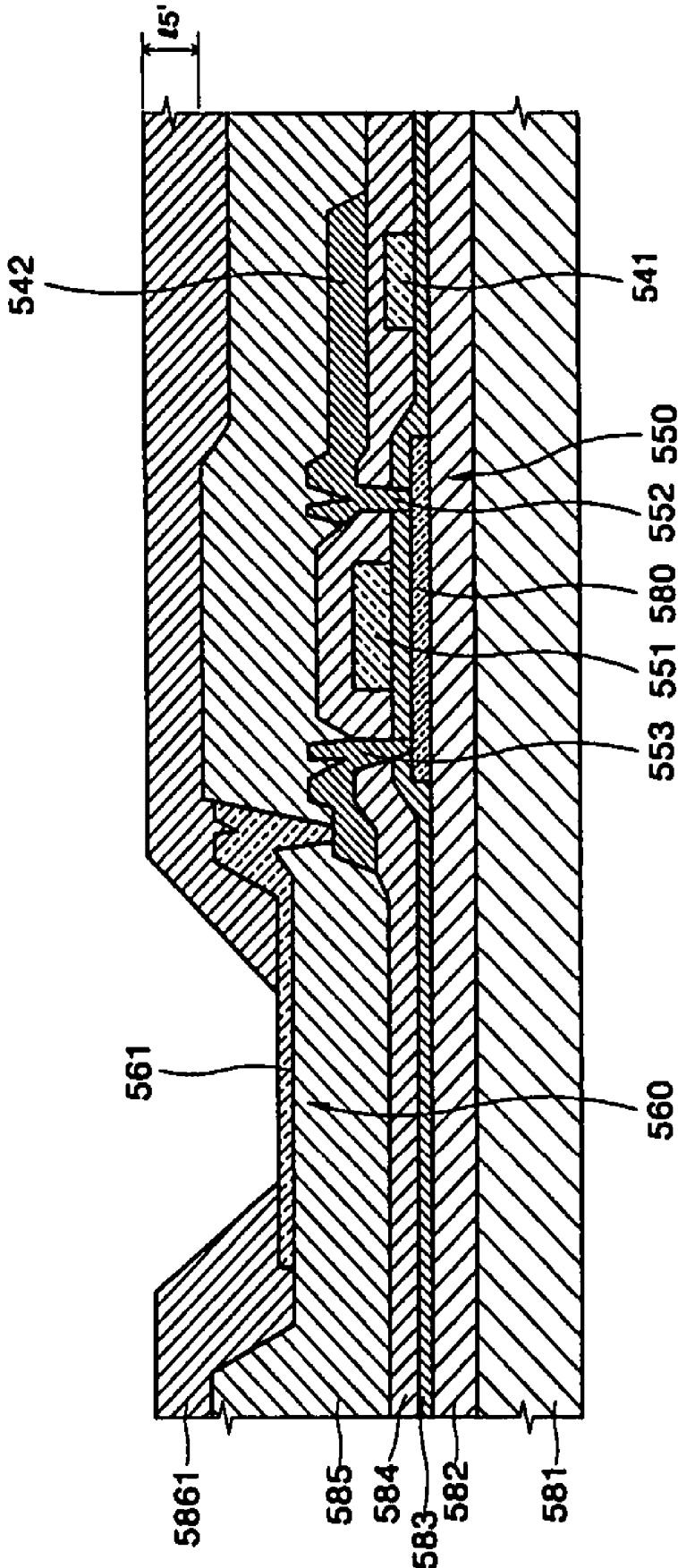

FIG. 17

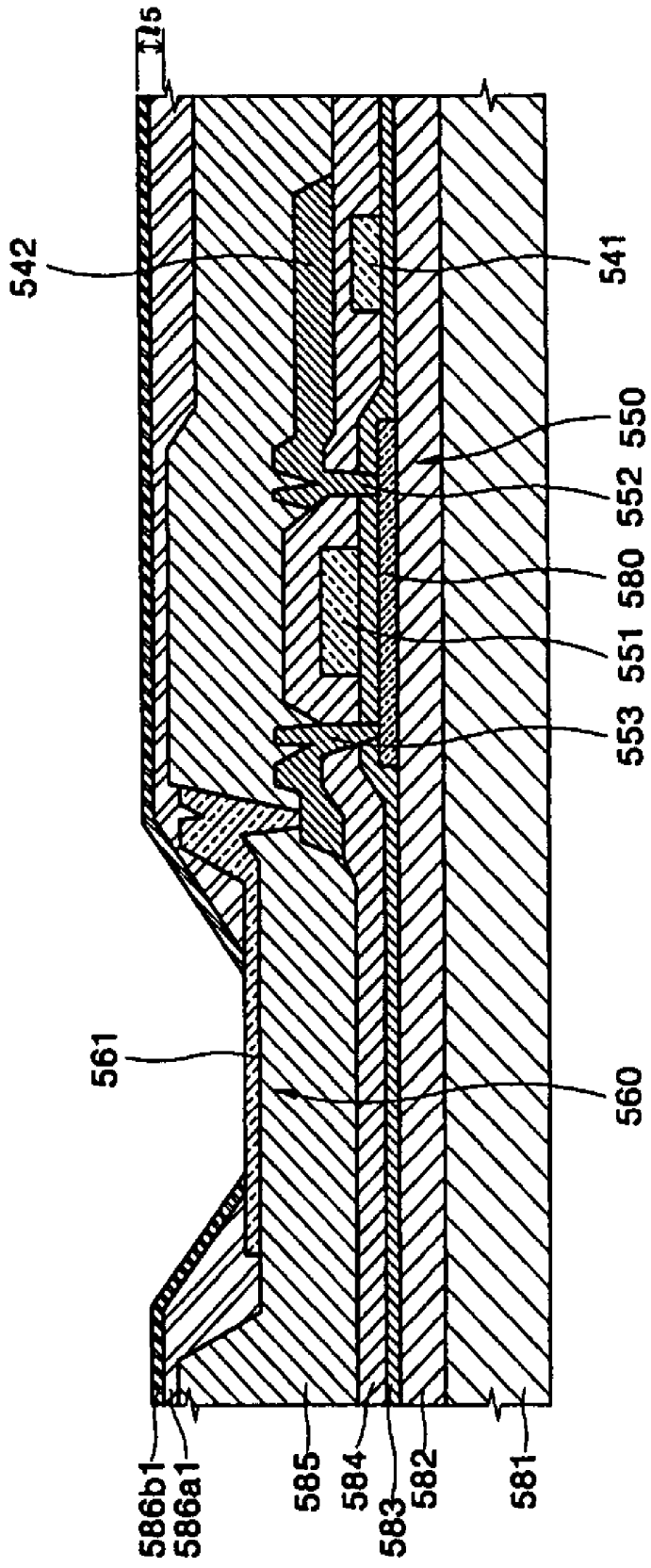

FIG. 18

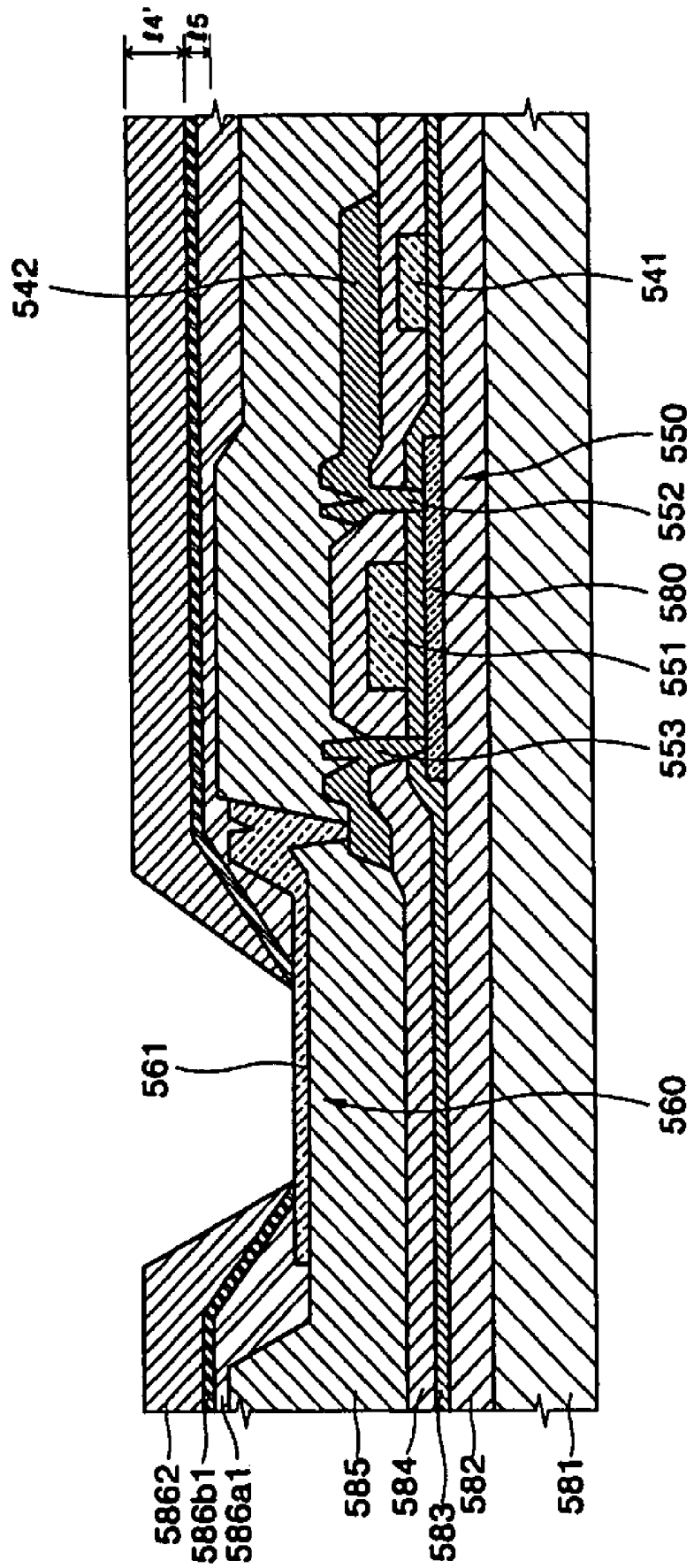

FIG. 19

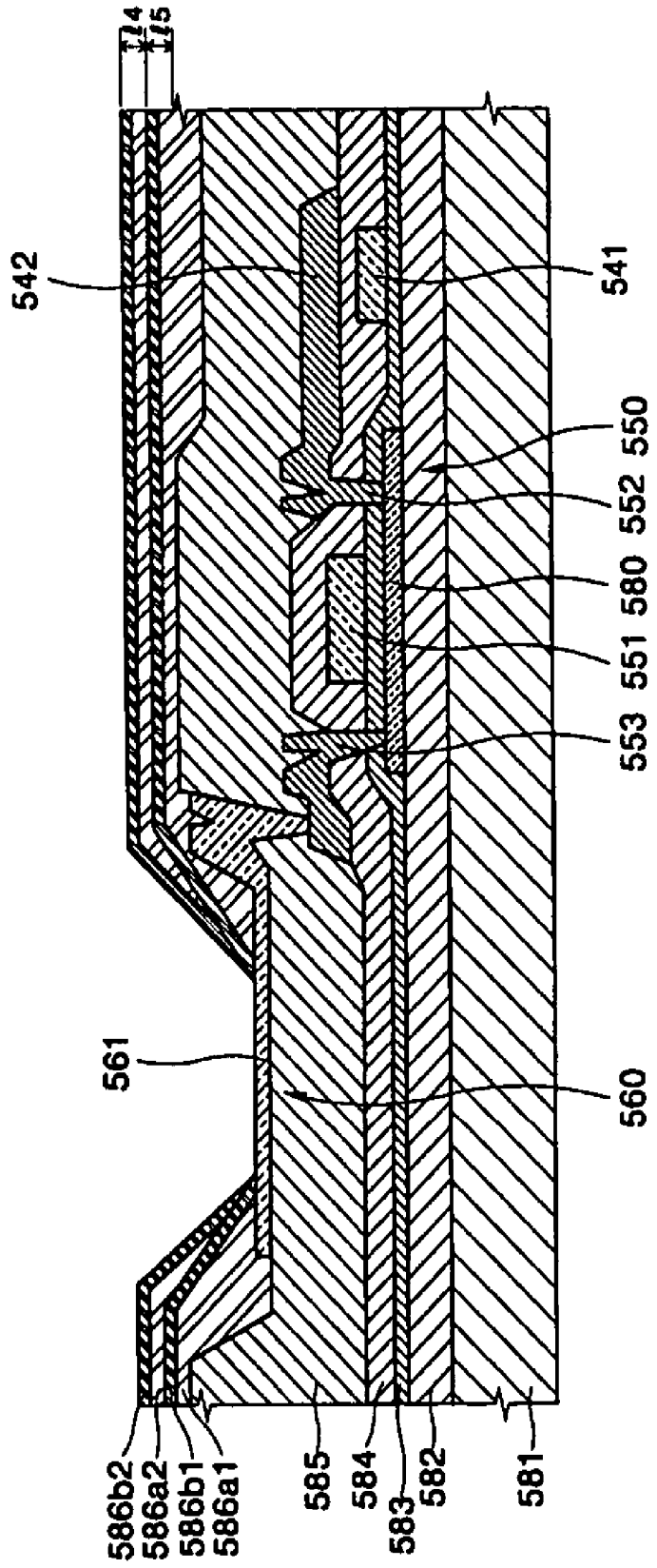
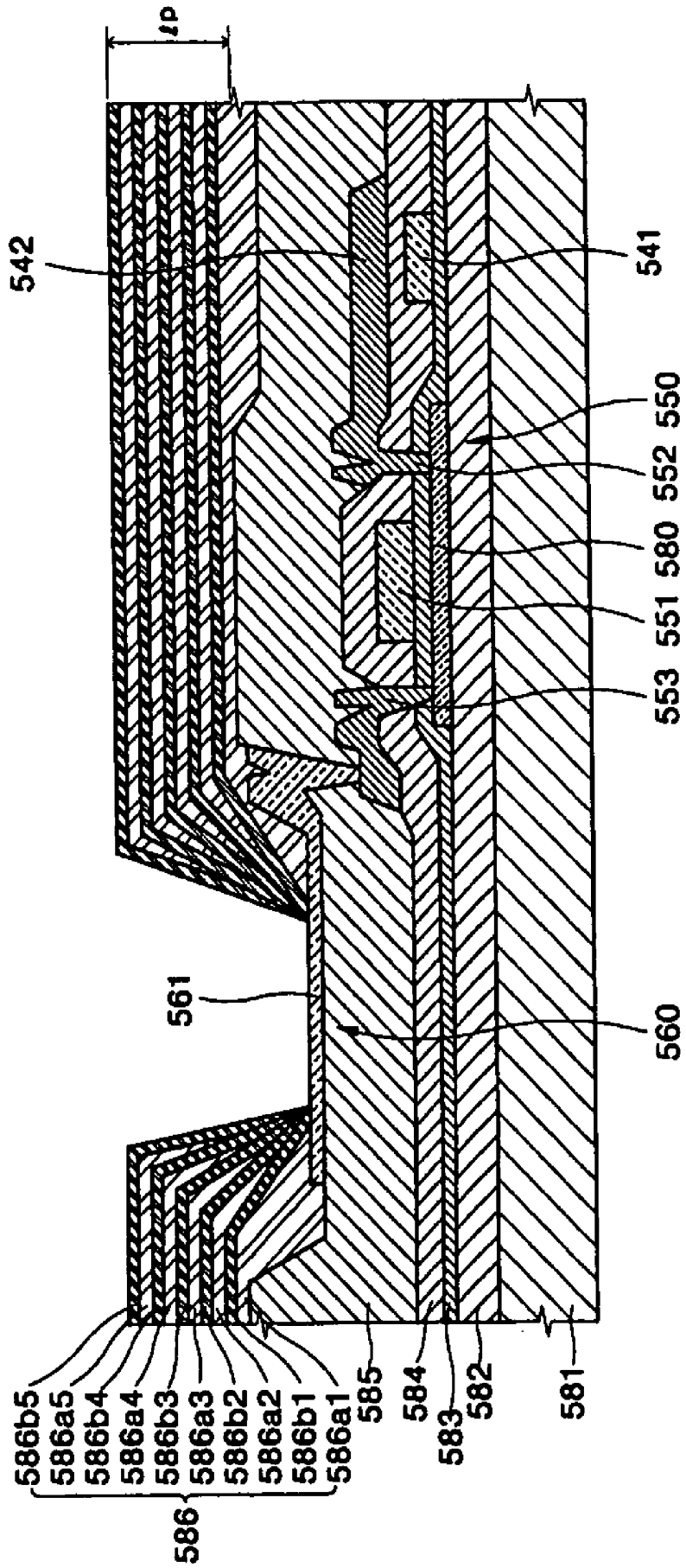

FIG. 20



## ELECTROLUMINESCENT DISPLAY DEVICE AND METHOD OF FABRICATING THE SAME

### CROSS-REFERENCE TO RELATED APPLICATION

[0001] This application claims the benefit of Korean Patent Application Nos. 10-2004-0041066, filed on Jun. 4, 2004, and 10-2004-0049709, filed on Jun. 29, 2004, which are hereby incorporated by reference for all purposes as if fully set forth herein.

### BACKGROUND OF THE INVENTION

[0002] 1. Field of the Invention

[0003] The present invention relates to an electroluminescent (EL) display device and a method of fabricating the same and, more particularly, to an EL display device, which includes a pixel defining layer with at least one barrier layer to reduce the amount of outgas from the pixel defining layer and prevent the degradation of an emission portion due to the outgas, and a method of fabricating the same.

[0004] 2. Description of the Related Art

[0005] Thin and lightweight portable display devices that quickly process a great deal of information are being rapidly developed as the demand for prompt and accurate information increases. Conventional cathode ray tubes (CRT) are heavy, take up a lot of space, and consume a lot of power, and a liquid crystal display (LCD) is complex to manufacture, it has a narrow viewing angle, and it has technical limits in contrast ratio and scaling-up.

[0006] On the other hand, an organic EL display device is a self-emissive device in which electrons and holes recombine in an organic emitting layer to generate light. Therefore, not only may the organic EL display device be made lightweight and thin, it may be made with a simpler process since a separate light source is not required unlike an LCD. Furthermore, the organic EL display device has as fast a response speed as a CRT and consumes less power than the CRT. Consequently, the organic EL display device is being considered as a primary next-generation display.

[0007] FIG. 1 is a plan view showing a pixel consisting of red (R), green (G) and blue (B) unit pixels of a conventional electro luminescent display device.

[0008] Referring to FIG. 1, scan lines 1 may be arranged in a row direction, data lines 2 may be arranged in a column direction and insulated from the scan lines 1, and common power supply voltage lines 3 may be arranged in the column direction, insulated from the scan lines 1 and parallel to the data lines 2. Accordingly, the scan lines 1, the data lines 2 and the common power supply voltage lines 3 define a plurality of unit pixels, such as, for example, R, G, B unit pixels.

[0009] Each unit pixel may comprise a switching thin film transistor (TFT) 5, a driving TFT 6, a capacitor 7, and an organic light emitting diode 9.

[0010] In each unit pixel, data signals from the data lines 2 according to scan signals from the scan lines 1, for example, electric charges according to a difference between a data voltage and a voltage from the common power supply voltage lines 3, accumulate in the capacitor 7, and signals by

the electric charges accumulated in the capacitor 7 are input into the driving TFT 6 through the switching TFT 5. Subsequently, the driving TFT 6 receives the data signals and sends electrical signals to a pixel electrode 8, so that the organic light emitting diode 9, which comprises an organic emission layer formed between the pixel electrode 8 and an opposing electrode, emits light.

[0011] FIG. 2 is a cross-sectional view showing an organic light emitting diode in an organic EL display device taken along line I-I' of FIG. 1.

[0012] Referring to FIG. 2, a substrate having R, G, and B unit pixels is provided.

[0013] A pixel electrode 8 may be formed on the substrate 10. Then, a pixel defining layer 12 is formed on the entire surface of the substrate 10 having the pixel electrode 8 to define a pixel region where an emission layer will be formed.

[0014] Here, the pixel defining layer 12 is generally formed of a photosensitive material. An opening part 11 exposing a part of the pixel electrode 8 may be formed by a photolithography process on the pixel defining layer 12.

[0015] After forming the opening part 11, the pixel defining layer 12 may be hardened at temperature of about 230° C. to 280° C. by baking to remove outgas remaining in the pixel defining layer 12.

[0016] An organic layer 13 including at least an organic emission layer may be formed on the surface of the substrate 10 having the opening part 11, and an opposing electrode 14 may then be formed on the organic layer 13 and sealed, thereby completing fabrication of the organic EL display device.

[0017] In addition to the organic emission layer, the organic layer 13 may further include at least one of a hole injection layer, a hole transport layer, a hole blocking layer, an electron transport layer, and an electron injection layer

[0018] However, the outgas cannot be completely removed even though the pixel defining layer 12 is hardened. Furthermore, short-term or long-term chemical decomposition may continuously generate outgas in the pixel defining layer 12.

[0019] The outgas may cause pixels to shrink, and it may lower the life cycle of an organic EL display device by deteriorating the organic emission layer. Furthermore, at high temperatures, a material in the pixel defining layer 12 can be decomposed into various molecules including functional groups. The functional groups may change the chemical structure of the organic emission layer, thereby negatively affecting the light emitting function of the organic emission layer, which may deteriorate the device's luminance and color purity.

[0020] While an inorganic layer may be used as the pixel defining layer 12 in order to solve the foregoing problems, the inorganic layer may complicate the fabrication process.

### SUMMARY OF THE INVENTION

[0021] The present invention, therefore, solves aforementioned problems associated with conventional devices and methods by providing an EL display device and a method of fabricating the same, in which a pixel define layer comprises

at least one barrier layer to reduce the amount of outgas from the pixel defining layer and prevent the degradation of an organic layer due to the outgas.

[0022] In an exemplary embodiment of the present invention, an EL display device includes: a substrate; a plurality of pixel electrodes disposed on the substrate; a pixel defining layer disposed on the pixel electrodes and having an opening part exposing a predetermined part of each of the pixel electrodes; and

[0023] at least one barrier layer disposed in and/or on the pixel defining layer.

[0024] In another exemplary embodiment of the present invention, an EL display device includes: a substrate; a plurality of pixel electrodes disposed on the substrate; a plurality of pixel defining layers disposed on the pixel electrodes and having an opening part exposing a predetermined part of each of the pixel electrodes; and at least one barrier layer disposed in and/or on each of the pixel defining layers.

[0025] In another exemplary embodiment of the present invention, a method of fabricating an EL display device includes: forming a pixel electrode on a substrate; forming a pixel defining layer on the entire surface of the substrate having the pixel electrode, the pixel defining layer having an opening part exposing a predetermined part of the pixel electrode; forming a barrier layer by injection impurities into onto the pixel defining layer; forming an emission layer layer on the exposed part of the pixel electrode; and forming an opposing electrode on the organic layer.

[0026] In another exemplary embodiment of the present invention, a method of fabricating an EL display device includes: forming a pixel electrode on a substrate; forming a pixel defining layer on the entire surface of the substrate having the pixel electrode, the pixel defining layer having an opening part exposing a predetermined part of the pixel electrode; forming a barrier layer by heat curing a part of the pixel defining layer; forming an emission layer on the exposed part of the pixel electrode; and forming an opposing electrode on the organic layer.

#### BRIEF DESCRIPTION OF THE DRAWINGS

[0027] The above and other features of the present invention will be described in reference to certain exemplary embodiments thereof with reference to the attached drawings in which:

[0028] FIG. 1 is a plan view showing a pixel consisting of red (R), green (G) and blue (B) unit pixels of a conventional EL display device;

[0029] FIG. 2 is a cross-sectional view taken along line I-I' of FIG. 1;

[0030] FIGS. 3A through 3C are cross-sectional views of an EL display device according to an exemplary embodiment of the present invention;

[0031] FIG. 4 is a photograph of a barrier layer obtained after injecting impurities onto an upper part of a pixel defining layer;

[0032] FIG. 5 is a cross-sectional view of an EL display device according to another exemplary embodiment of the present invention;

[0033] FIG. 6 is a cross-sectional view of an EL display device according to still another exemplary embodiment of the present invention;

[0034] FIG. 7 is a cross-sectional view of an EL display device according to yet another exemplary embodiment of the present invention;

[0035] FIG. 8 is a cross-sectional view of an EL display device according to further another exemplary embodiment of the present invention;

[0036] FIG. 9 is a cross-sectional view of an EL display device according to still further another exemplary embodiment of the present invention;

[0037] FIGS. 10, 11, and 13 through 15 are cross-sectional views for explaining a method of fabricating an EL display device according to an exemplary embodiment of the present invention;

[0038] FIG. 12 is a photograph of a double barrier layer obtained after heat curing a material for a pixel defining layer; and

[0039] FIGS. 16 through 20 are cross-sectional views for explaining a method of fabricating an EL display device according to another exemplary embodiment of the present invention.

#### DETAILED DESCRIPTION

[0040] The present invention will now be described more fully hereinafter with reference to the accompanying drawings, in which exemplary embodiments of the invention are shown.

[0041] FIG. 3A through FIG. 3C are cross-sectional views for explaining an EL display device and method for fabricating the same according to an exemplary embodiment of the present invention.

[0042] Referring to FIG. 3A, a substrate 100 is provided. A buffer layer 110, which may be, for example, a silicon oxide layer, a silicon nitride layer or a laminated layer of the silicon oxide layer and the silicon nitride layer, may be formed on the substrate 100 to block impurities from flowing out of an upper part of the substrate 100.

[0043] After forming the buffer layer 110, a polysilicon layer 125 may be formed by crystallizing amorphous silicon on the buffer layer 110.

[0044] A gate insulation layer 120 may then be formed on the substrate 100 having the polysilicon layer 125, and a gate electrode 135 may be formed on the gate insulation layer 120 at a region corresponding to a channel region 125b of the polysilicon layer 125.

[0045] Then, the polysilicon layer 125 may be doped with ions to form a semiconductor layer 125 including a drain region 125a, a source region 125c and the channel region 125b.

[0046] An interlayer insulation layer 130 may then be formed on the gate insulation layer 120 and the gate electrode 135, and contact holes for exposing parts of the drain region 125a and the source region 125c are etched in the gate insulation layer 120 and the interlayer insulation layer 130.

[0047] Next, source and drain electrodes **145** may be formed on the interlayer insulation layer **130**. The source and drain electrodes **145** are connected to the source and drain regions **125c** and **125a**, respectively, through the contact holes.

[0048] After forming the source and drain electrodes **145**, a passivation insulation layer **140** may be formed on the interlayer insulation layer **130** and the source and drain electrodes **145**. The passivation insulation layer **140** can be, for example, an SiO<sub>2</sub>, SiN<sub>x</sub> or SiO<sub>2</sub>/SiN<sub>x</sub> laminated layer.

[0049] Furthermore, a planarization layer **150** may be formed on the passivation insulation layer **140** to flatten a bump generated due to the underlying TFT.

[0050] The planarization layer **150** can be formed of, for example, polyamide resin, polyimide resin, acryl resin, and silicon based resin.

[0051] After forming the planarization layer **150**, a via hole **155** may be formed by etching the planarization layer **150** and the passivation layer **140** to expose one of the source and drain electrodes **145**. FIG. 3A shows the via hole **155** exposing a part of the drain electrode **145**.

[0052] Next, a pixel electrode **165** may be formed so that it is coupled to the source or drain electrode **145** that is exposed by the via hole **155**.

[0053] If the pixel electrode **165** acts as an anode, the pixel electrode **165** may be a transparent electrode formed of, for example, indium tin oxide (ITO) or indium zinc oxide (IZO), or it may be formed as a reflection electrode using Pt, Au, Ir, Cr, Mg, Ag, Ni, Al or an alloy thereof as a metal having a high work function.

[0054] Furthermore, if the pixel electrode **165** acts as the cathode, the pixel electrode **165** may be formed as a thin transparent electrode or a thick reflection electrode formed of Mg, Ca, Al, Ag, Ba or alloy thereof as a metal having a low work function.

[0055] A pixel defining layer **160** may then be formed by a spin coating or dip coating process on the substrate **100** having the pixel electrode **165**.

[0056] Additionally, the pixel defining layer **160** may be formed about 1000 to about 5000 Å thick considering the thickness of an organic layer that will be formed later using a laser induced thermal imaging (LITI) process.

[0057] The pixel defining layer **160** may be formed of, for example, one material selected from the group consisting of polystyrene, polymethylmethacrylate, polyacrylonitrile, polyamide, polyimide, polyarylether, heterocyclic polymer, parylene, fluorine polymer, epoxy resin, benzocyclobutene based resin, siloxane based resin, and silane resin.

[0058] After forming the pixel defining layer **160**, as shown in FIG. 3B, an opening part **A** for exposing a part of the pixel electrode **165** may be formed by patterning the pixel defining layer **160** through an ordinary photolithography process.

[0059] The pixel defining layer **160** passes through a bake process at a temperature of about 230° C. to 260° C. to remove outgas remaining in the pixel defining layer **160**. However, the baking process may not completely remove all

outgas, thereby adversely affecting the light emitting function of an organic EL display device.

[0060] Therefore, a barrier layer **160'** may be formed on the pixel defining layer **160** pattern to prevent outgas generated from the pixel defining layer **160** from permeating an organic emission layer.

[0061] The barrier layer **160'** may be formed by curing an upper part of the existing pixel defining layer **160** pattern by injecting impurities X onto the pixel defining layer **160**.

[0062] The impurities X can be, for example, ions or inert gas.

[0063] The ions can be ions of one element selected from the group consisting of B, P and As. The ions may be injected onto the pixel defining layer **160** to a dose amount of about 10<sup>14</sup> to 10<sup>15</sup> ions/cm<sup>2</sup> at an acceleration energy of about 75 to about 85 keV using an ion injector, such as, for example, an ion shower or implantation process.

[0064] On the other hand, the inert gas can be a gas selected from the group consisting of Ar, He, Xe, H<sub>2</sub>, and Ne. The inert gas may be accelerated onto the pixel defining layer **160** at a flow rate of at least 50 sccm (standard cubic centimeters per minute) at an electric power of about 100 W in a vacuum of about 10 to 400 mtorr using sputtering equipment, such as, for example, an etcher or asher.

[0065] The thicker the barrier layer **160'** is formed, the more it is capable of preventing outgas from permeating into an organic emission layer. However, although the barrier layer may be formed thick using high energy or increasing the concentration of impurities, this may increase production cost, since expensive equipment may be required, or increase fabrication time, thereby lowering productivity.

[0066] Therefore, the thickness of the barrier layer **160'** may be about 10% or less of the thickness of the pixel defining layer **160**.

[0067] Also, the barrier layer **160'** may be formed on the pixel defining layer **160**, is naturally formed by heat curing the pixel defining layer **160**. In this case, the pixel defining layer **160** may be heat cured by performing an annealing process in a vacuum oven or furnace. The barrier layer **160'** on the pixel defining layer may be formed by heat curing the pixel defining layer until the pixel defining layer shrinks to about 50% of an original thickness of the pixel defining layer.

[0068] Subsequently, as shown in FIG. 3C, an emission layer **170** having at least an emission layer may be formed on the pixel electrode **165** and the pixel defining layer **160**.

[0069] In an organic EL display device, the emission layer **170** may be formed of a small molecule organic layer or polymer organic layer.

[0070] When the emission layer **170** is a small molecule organic layer, the organic layer **170** may include one or more of layers such as a hole injection layer (HIL), hole transport layer (HTL), emission layer (EML), electron transport layer (ETL), and electron injection layer (EIL). The emission layer **170** may be formed of various organic materials, such as, for example, copper phthalocyanine (CuPc), N,N'-Di-(naphthalene-1-yl)-N,N'-diphenyl-benzidine (NPB), or tris-8-hydroxyquinoline aluminum (Alq3). When electric charges are supplied to the pixel electrode **165** and an

opposing electrode, holes and electrons recombine to generate excitons. As the excitons are changed from an excited state to a ground state, the emission layer (EML) emits light.

[0071] Of course, the structure of the small molecule organic layer is not limited to the above description, but the emission layer 170 can include various layers according to purposes.

[0072] When the emission layer 170 is a polymer organic layer, the organic layer 170 may generally include a polymer HTL and a polymer EML. The polymer HTL may be formed of poly-(2,4)-ethylene-dihydroxy thiophene (PEDOT) or polyaniline (PANI) using an inkjet printing or spin coating process. The polymer EML may be formed of PPV, soluble PPV's, Cyano-PPV, or polyfluorene. Of course, the structure of the polymer organic layer is not limited to the above description, but the emission layer 170 can include various layers according to purposes.

[0073] Also, the EML may be formed as a color pattern by an ordinary method, such as, for example, an depositing, an inkjet printing or spin coating process or LITI process.

[0074] In the case of an inorganic light emitting display device, the emission layer may be formed of an inorganic layer instead of the above-described organic layer, and the inorganic layer may include an emission layer and an insulation layer interposed between the emission layer and an electrode. Of course, the structure of the inorganic layer is not limited to the above description, but the inorganic layer may include various layers according to purposes. In the inorganic light emitting display device, the emission layer may be formed of a metal sulfide, such as ZnS, SrS, or CaS, or an alkaline earths kalium sulfide, such as  $\text{CaGa}_2\text{S}_4$  or  $\text{SrGa}_2\text{S}_4$ , and emission-atoms of a transitional metal or alkaline rare-earth metal including Mn, Ce, Tb, Eu, Tm, Er, Pr, and Pb.

[0075] An opposing electrode 180 may then be formed on the emission layer 170.

[0076] If the opposing electrode 180 acts as a cathode, the opposing electrode 180 may be formed as a thin transparent electrode or a thick reflection electrode formed of Li, LiF/Ca, LiF/Al, Mg, Ca, Al, Ag or an alloy thereof as a conductive metal having a low work function.

[0077] Furthermore, if the opposing electrode 180 acts as an anode, the opposing electrode 180 can be a transparent electrode formed of ITO or IZO, or a reflection electrode formed of Pt, Au, Ir, Cr, Mg, Ag, Ni, Al or an alloy thereof as a metal having a high work function.

[0078] Although not shown in the drawings, an EL display device can be fabricated by sealing the opposing electrode 180 using a sealant, such as an upper metal can.

[0079] FIG. 4 is a photograph of a barrier layer obtained after impurities are doped on an upper part of a pixel defining layer.

[0080] As shown in FIG. 4, about a 2,800 Å thick barrier layer 160' may be formed by injecting P ions onto the pixel defining layer at a dose amount of about  $10^{15}$  ions/cm<sup>2</sup> at an acceleration energy of about 75 keV.

[0081] As described above, an EL display device with the barrier layer may be formed by doping impurities on the

pixel defining layer without adding a separate mask process according to the present invention.

[0082] An EL display device according to the present invention may minimize thermal strain stress of a pixel defining layer due to the external environment by forming the barrier layer and prevent degradation of the organic emission layer and contraction of pixels by preventing outgas from permeating into the organic emission layer.

[0083] According to the present invention, the barrier layer 160' is formed in the pixel defining layer 160 to prevent generation of outgas. Thus, the area of a region where outgas may be generated is comparatively reduced in the pixel defining layer 160, thereby ultimately decreasing the amount of outgas. Also, since the pixel defining layer 160 includes the barrier layer 160', it is possible to prevent outgas generated in the pixel defining layer 160 from being discharged and adversely affecting an EL display device. In particular, the outgas generated in the pixel defining layer 160 should go round the barrier layer 160' in order that it may be discharged out of the pixel defining layer 160. That is, the present invention makes a discharge path of the outgas longer, thus suppressing the discharge of the outgas.

[0084] Furthermore, in the above-described structure, since the barrier layer 160' is disposed on the surface of the pixel defining layer 160, the outgas generated in the pixel defining layer 160 is not discharged out of the pixel defining layer 160.

[0085] FIG. 5 is a cross-sectional view of an EL display device according to another exemplary embodiment of the present invention.

[0086] Referring to FIG. 5, pixel defining layers 286 are disposed between display portions 260, more specifically, between pixel electrodes 261. The present embodiment differs from the first embodiment in that on each of the pixel defining layers 286 comprise a double barrier layer 286b1 and 286b2.

[0087] In the present embodiment, the double barrier layer 286b1 and 286b2 are disposed in the pixel defining layer 286 to prevent generation of outgas.

[0088] Thus, the area of a region where outgas may be generated is comparatively reduced in the pixel defining layer 286, thereby ultimately decreasing the amount of outgas. Also, since the pixel defining layer 286 includes the double barrier layer 286b1 and 286b2, it is possible to prevent outgas generated in the pixel defining layer 286 from being discharged and adversely affecting an EL display device. In particular, the outgas generated in the pixel defining layer 286 should go round the double barrier layer 286b1 and 286b2 in order that it may be discharged out of the pixel defining layer 286. That is, the present invention makes a discharge path of the outgas longer, thus suppressing the discharge of the outgas.

[0089] Unlike in FIG. 5, the pixel defining layer 286 may comprise three or more barrier layers in the pixel defining layer.

[0090] FIG. 6 is a cross-sectional view of an EL display device according to still another exemplary embodiment of the present invention.

[0091] Referring to FIG. 6, pixel defining layers 386 are disposed between display portions 360, more specifically,

between pixel electrodes **361**. The present embodiment differs from the first and second embodiments in that each of the pixel defining layers **386** includes three or more barrier layers **386b1**, **386b2**, **386b3**, **386b4**, and **386b5**. In particular, as shown in **FIG. 6**, the barrier layers **386b1**, **386b2**, **386b3**, **386b4**, and **386b5** are disposed parallel to each other so that they form an on ion shape.

[**0092**] In the present embodiment, a plurality of barrier layers **386b1**, **386b2**, **386b3**, **386b4**, and **386b5** are disposed in the pixel defining layer **386** to prevent generation of outgas. Thus, the area of a region where outgas may be generated is comparatively reduced in the pixel defining layer **386**, thereby ultimately decreasing the amount of outgas.

[**0093**] Also, since the pixel defining layer **386** includes the barrier layers **386b1**, **386b2**, **386b3**, **386b4**, and **386b5**, it is possible to prevent outgas generated in the pixel defining layer **386** from being discharged and adversely affecting an EL display device. In particular, the outgas generated in the pixel defining layer **386** should go round the multiple barrier layer **386b1**, **386b2**, **386b3**, **386b4**, and **386b5** in order that it may be discharged out of the pixel defining layer **386**. That is, the present invention makes a discharge path of the outgas longer, thus suppressing the discharge of the outgas.

[**0094**] **FIG. 7** is a cross-sectional view of an EL display device according to yet another exemplary embodiment of the present invention.

[**0095**] Referring to **FIG. 7**, pixel defining layers **486** are disposed between display portions **460**, more specifically, between pixel electrodes **461**. The present embodiment differs from the first, second, and third embodiments in that edge portions of the barrier layers **486b1**, **486b2**, **486b3**, **486b4**, and **486b5** are adjacent to one another.

[**0096**] In the present embodiment, a plurality of barrier layers **486b1**, **486b2**, **486b3**, **486b4**, and **486b5** are comprised in the pixel defining layer **486** to prevent generation of outgas. Thus, the area of a region where outgas may be generated is comparatively reduced in the pixel defining layer **486**, thereby ultimately decreasing the amount of outgas.

[**0097**] Also, since the barrier layers **486b1**, **486b2**, **486b3**, **486b4**, and **486b5**, it is possible to prevent outgas generated in the pixel defining layer **486** from being discharged and adversely affecting an EL display device. In particular, the outgas generated in the pixel defining layer **486** should go round the multiple barrier layer **486b1**, **486b2**, **486b3**, **486b4**, and **486b5** in order that it may be discharged out of the pixel defining layer **486**. That is, the present invention makes a discharge path of the outgas longer, thus suppressing the discharge of the outgas.

[**0098**] On the other hand, since the edge portions of the barrier layers **486b1**, **486b2**, **486b3**, **486b4**, and **486b5** are adjacent to one another as described above, a part of the pixel defining layer **486**, which is adjacent to the display portion **460**, is comprised of only the barrier layers **486b1**, **486b2**, **486b3**, **486b4**, and **486b5**. Thus, even if outgas is generated in the pixel defining layer **486**, it is possible to prevent the outgas from negatively affecting the display portion **460**.

[**0099**] **FIG. 8** is a cross-sectional view of an EL display device according to further another exemplary embodiment of the present invention.

[**0100**] Referring to **FIG. 8**, pixel defining layers **586** are disposed between display portions **560**, more specifically, between pixel electrodes **561**. The present invention differs from the above-described embodiments in that three or more barrier layers **586b1**, **586b2**, **586b3**, **586b4**, and **586b5** formed on each of the pixel defining layers **586**. In particular, as shown in **FIG. 8**, edge portions of the barrier layers **586b1**, **586b2**, **586b3**, **586b4**, and **586b5** are adjacent to one another.

[**0101**] The main difference between the present embodiment and the fourth embodiment as described with reference to **FIG. 7** is the shape of edge portions of barrier layers included in a pixel defining layer. In the EL display device of the fourth embodiment, the part of the pixel defining layer, which is adjacent to the display portion, is comprised of only barrier layers. However, because the edge portions of the barrier layers are adjacent to one another, the total thickness of parts of barrier layers, which are adjacent to the display portion, becomes great, so that the display portion may be narrow.

[**0102**] In comparison, in the EL display device of the present embodiment, the edge portions of the barrier layers **586b1**, **586b2**, **586b3**, **586b4**, and **586b5** overlap one another. Thus, since a part of the pixel defining layer **586**, which is adjacent to the display portion **560**, is comprised of only the barrier layers **586b1**, **586b2**, **586b3**, **586b4**, and **586b5**, even if outgas is generated in the pixel defining layer **586**, it is possible to prevent the outgas from negatively affecting the display portion **560**. Furthermore, the total thickness of parts of the barrier layers **586b1**, **586b2**, **586b3**, **586b4**, and **586b5**, which are adjacent to the display portion **560**, can be held constant, so that the display portion **560** is not narrowed.

[**0103**] On the other hand, in the foregoing embodiments, it is important to appropriately control the thickness of a pixel defining layer. Hereinafter, a method for controlling the thickness of the pixel defining layer will be described.

[**0104**] Referring to **FIG. 9**, which shows the EL display device as described with reference to **FIG. 6**, each of the sums **11**, **12**, **13**, **14**, and **15** of a distance between the barrier layers **386b1**, **386b2**, **386b3**, **386b4**, and **386b5** included in each pixel defining layer **386** and the thicknesses of the respective barrier layers **386b1**, **386b2**, **386b3**, **386b4**, and **386b5** may be about 1000 Å.

[**0105**] When each of the sums **11**, **12**, **13**, **14**, and **15** is far more than 1000 Å, the final thickness of the pixel defining layer **386** including the multiple barrier layer becomes too great, is thus complicating a subsequent process that will be described later. Therefore, each of the sums **11**, **12**, **13**, **14**, and **15** may be about 1000 Å. Also, when each of the sums **11**, **12**, **13**, **14**, and **15** is far less than 1000 Å, each of the barrier layers **386b1**, **386b2**, **386b3**, **386b4**, and **386b5** may be cut or deformed. As a result, it becomes difficult to prevent outgas generated in the pixel defining layer **386** from being discharged and affecting the display portion. Consequently, each of the sums **11**, **12**, **13**, **14**, and **15** may be about 1000 Å.

[**0106**] On the other hand, in the fabrication of an EL display device, after forming the foregoing pixel defining

layer **386**, a process of forming an organic layer including at least an EML between a pixel electrode and an opposing electrode is performed. In this process, when the organic layer is formed of a small molecule organic material, each layer may be formed using a vacuum evaporation method. However, if the organic layer is formed of a polymer organic material by a vacuum evaporation method using a mask, there are technical limits in minimizing a physical gap, it is difficult to apply the organic layer to an EL display device having several-tens- $\mu\text{m}$  fine patterns due to the deformation of the mask, and the organic layer has technical limits in scaling-up.

[0107] In order to overcome these drawbacks, the organic layer may be coated using a spin coating process and finely patterned using a lithography process in which a photoresist layer is coated on the organic layer, exposed, and developed. However, in this case, since organic layers may be deformed by organic solvents and remnants of a developing solution, which are used in the lithography process, it is almost impossible to use the lithography process to pattern the organic layer.

[0108] Accordingly, in order to solve the above-described problems, a method of forming a display portion including an organic layer through a LITI process was developed.

[0109] In the LITI process, when a laser is used as an energy source that irradiates light onto a donor film, beams of the laser of which focus is controlled to a predetermined value are scanned onto the donor film according to desired patterns to coat an organic layer. Thus, the organic layer can be finely patterned through the focusing of the laser.

[0110] However, as described above, when a region where the organic layer will be formed and a transfer layer of the donor film are disposed opposite each other and laminated, if there is any protrusion on the surface of the region where the organic layer will be formed, the organic layer and the transfer layer cannot be precisely aligned to each other and the organic layer cannot be exactly transferred.

[0111] As described above, the process of forming the organic layer using the LITI process is performed after the pixel defining layer is formed. Therefore, as shown in FIG. 9, since the defining layer **386** protrudes over the display portion **360**, the pixel defining layer **386** may be formed to a thickness of 5000 Å or less to solve the above-described problems.

[0112] When a conventional pixel defining layer, which is about 1.5 to 2  $\mu\text{m}$  thick, is used, an organic layer cannot be desirably formed using the LITI process. Accordingly, the pixel defining layer **386** may be formed to a thickness  $l_p$  of about 5000 Å or less.

[0113] In this case, considering that each of the sums **11**, **12**, **13**, **14**, and **15** of a distance between the barrier layers **386b1**, **386b2**, **386b3**, **386b4**, and **386b5** included in each pixel defining layer **386** and the thicknesses of the respective barrier layers **386b1**, **386b2**, **386b3**, **386b4**, and **386b5** is about 1000 Å as described above, the number of the barrier layers **386b1**, **386b2**, **386b3**, **386b4**, and **386b5** included in the pixel defining layer **386** may be 5 or fewer.

[0114] FIGS. 10, 11, and 13 through 15 are cross-sectional views for explaining a method of fabricating an EL display device according to an exemplary embodiment of the

present invention. More specifically, a process of forming a pixel defining layer including a barrier layer will now be described.

[0115] Referring to FIG. 10, to fabricate the EL display device, a predetermined pattern of a pixel electrode **361** is formed on a substrate **381**, and then a pixel defining layer **3861** is formed on the entire surface of the substrate **381** and patterned to expose a part of the pixel electrode **361**. Of course, before forming the predetermined pattern of the pixel electrode **361** on the substrate **381**, a TFT **350** and a storage capacitor may be formed on the substrate **381**. Also, after forming an opposing electrode, a passivation layer or a front substrate may be formed.

[0116] After patterning the pixel defining layer **3861**, as shown in FIG. 11, a barrier layer **386b1** is formed on the pixel defining layer **3861**, an organic layer including at least an EML is formed on the exposed part of the pixel electrode **361**, and an opposing electrode is formed on the organic layer.

[0117] The pixel defining layer **3861** may be formed of, for example, one material selected from the group consisting of polystyrene, polymethylmethacrylate, polyacrylonitrile, polyamide, polyimide, polyarylether, heterocyclic polymer, parylene, fluorine polymer, epoxy resin, benzocyclobutene based resin, siloxane based resin, and silane resin.

[0118] The barrier layer **386b1** may be formed by hardening an upper part of the existing pixel defining layer **3861** pattern by injecting impurities X onto the pixel defining layer **3861**.

[0119] The impurities X can be, for example, ions or inert gas.

[0120] The ions can be ions of one element selected from the group consisting of B, P and As. The ions may be injected onto the pixel defining layer **160** to a dose amount of about  $10^{14}$  to  $10^{15}$  ions/cm<sup>2</sup> at an acceleration energy of about 75 to about 85 keV using an ion injector, such as, for example, an ion shower or implantation process.

[0121] On the other hand, the inert gas can be a gas selected from the group consisting of Ar, He, Xe, H<sub>2</sub>, and Ne. The inert gas may be accelerated onto the pixel defining layer **160** at a flow rate of at least 50 sccm (standard cubic centimeters per minute) at an electric power of about 100 W in a vacuum of about 10 to 400 mtorr using sputtering equipment, such as, for example, an etcher or asher.

[0122] The thicker the barrier layer **386b1** is formed, the more it is capable of preventing outgas from permeating into an organic emission layer. However, although the barrier layer may be formed thick using high energy or increasing the concentration of impurities, this may increase production cost, since expensive equipment may be required, or increase fabrication time, thereby lowering productivity.

[0123] Therefore, the thickness of the barrier layer **160** may be about 10% or less of the thickness of the pixel defining layer **3861**.

[0124] Also, the barrier layer **386b1** may be formed on the pixel defining layer **3861**, is naturally formed by heat curing the pixel defining layer **3861**. In this case, the pixel defining layer **3861** may be heat cured by performing an annealing process in a vacuum oven or furnace. The barrier layer

**386b1** on the pixel defining layer may be formed by heat curing the pixel defining layer until the pixel defining layer shrinks to about 50% of an original thickness of the pixel defining layer.

[0125] FIG. 12 is a photograph of the pixel defining layer **3861** including a double barrier layer obtained after the above-described heat curing process. Referring to FIG. 12, a lower barrier layer is formed to a thickness of about 500 to 1000 Å, an upper barrier layer is formed to a thickness of about 1000 to 1500 Å, and the total thickness of the pixel defining layer **3861** is about 1.5 μm.

[0126] On the other hand, in order to form the pixel defining layer **3861** including a multiple barrier layer, the above-described process may further include a process of forming a pixel defining layer **3862** on the entire surface of the substrate **381** as shown in FIG. 13, a process of patterning the pixel defining layer **3862** to expose a part of the pixel electrode **361**, and a process of forming a barrier layer **386b2** on the pixel defining layer **3862** as shown in FIG. 14 after forming the barrier layer **386b1** on the pixel defining layer **3861** and before forming emission layer on the exposed part of the pixel electrode **361**. By performing the additional processes, a pixel defining layer including two barrier layers **386b1** and **386b2** may be formed as shown in FIG. 14.

[0127] Furthermore, before forming the emission layer on the exposed part of the pixel electrode **361**, the above-described additional processes may be repeated at least once, thus forming a plurality of barrier layers **386b1**, **386b2**, **386b3**, **386b4**, and **386b5** as shown in FIG. 15.

[0128] In the above-described processes, when the pixel defining layers **3861** and **3862** are coated on the entire surface of the substrate **381**, they may be coated to thicknesses **15'** and **14'** of about 2000 Å, respectively. In more detail, since the barrier layers **386b1** and **386b2** are formed on the pixel defining layers **3861** and **3862** using the heat curing process (i.e., the annealing process) as described above, the pixel defining layers **3861** and **3862** are thinned out during the annealing process. Therefore, in order that each of the sums **15** and **14** of a distance between the barrier layers **386b1** and **386b2** and the respective barrier layers **386b1** and **386b2** may be about 1000 Å as described above, the pixel defining layers **3861** and **3862** may be coated to thicknesses **15'** and **14'** of about 2000 Å and then plasticized to about 1000 Å.

[0129] On the other hand, the pixel defining layer **386** as shown in FIG. 15 includes barrier layers **386b1**, **386b2**, **386b3**, **386b4**, and **386b5**, which are parallel to one another. In order that the barrier layers **386b1**, **386b2**, **386b3**, **386b4**, and **386b5** may be parallel to one another, after forming the barrier layer **386b1** on the pixel defining layer **3861**, the process of patterning the pixel defining layer **3862** to expose the part of the pixel electrode **361** is performed such that the patterned pixel defining layer **3862** covers the pixel defining layer **3861** including the barrier layer **386b1**.

[0130] On the other hand, the edge portions of the barrier layers included in the pixel defining layer may be adjacent to one another as described above. The fabrication of such an EL display device will be described with reference to FIGS. 16 through 20, which are cross-sectional views for explaining a method of fabricating an EL display device according to another exemplary embodiment of the present invention.

[0131] As shown in FIG. 16, a pixel defining layer **5861** is coated on the entire surface of a substrate **581** to a thickness **15'** of about 2000 Å and patterned to expose a part of a pixel electrode **581**. Subsequently, the pixel defining layer **5861** is plasticized, thereby forming a first barrier layer **586b1** on the surface of the pixel defining layer **5861** as shown in FIG. 17. In this case, as described above, the pixel defining layer **5861** is plasticized to a thickness of about 1000 Å.

[0132] Thereafter, as shown in FIG. 18, a pixel defining layer **5862** is formed on the entire surface of the substrate **581** and patterned to expose a part of a pixel electrode **561**. During the patterning process, an edge portion of the barrier layer **586b1** disposed on the pixel defining layer **5861** is exposed. Subsequently, the pixel defining layer **5862** is heat cured, thereby forming a second barrier layer **586b2** on an upper part of the pixel defining layer **5862**. The above-described processes are repeated at least once, so that the pixel defining layer **586** includes a plurality of barrier layers **586b1**, **586b2**, **586b3**, **586b4**, and **586b5** and edge portions of the barrier layers **586b1**, **586b2**, **586b3**, **586b4**, and **586b5** are adjacent to one another.

[0133] On the other hand, although it is explained that the exemplary embodiments are applied to an active matrix EL display device, the present invention can be also applied to any EL display device including a pixel defining layer, such as a passive matrix EL display device.

[0134] As described above, according to the EL display device and method of fabricating the same of the present invention, the following effects can be obtained.

[0135] First, a pixel defining layer includes at least one barrier layer to prevent generation of outgas, so that the amount of outgas from the pixel defining layer can be reduced.

[0136] Second, since the pixel defining layer includes at least one barrier layer, the discharge of outgas generated in the pixel defining layer is blocked. As a result, it is possible to prevent the outgas from affecting and degrading a display portion including an EML.

[0137] Third, a discharge path of outgas generated in the pixel defining layer is extended owing to the pixel defining layer including at least one barrier layer. Thus, the discharge amount of the outgas can be minimized.

[0138] Fourth, the pixel defining layer is formed to a thickness of about 5000 Å or less. Thus, after forming the pixel defining layer, the EML of the display portion can be formed using an LITI process.

[0139] Although the present invention has been described with reference to certain exemplary embodiments thereof, it will be understood by those skilled in the art that a variety of modifications and variations may be made to the present invention without departing from the spirit or scope of the present invention defined in the appended claims, and their equivalents.

What is claimed is:

1. An electroluminescent (EL) display device comprising:
  - a substrate;
  - a plurality of pixel electrodes disposed on the substrate;

- a pixel defining layer disposed on the pixel electrodes and having an opening part exposing a predetermined part of each of the pixel electrodes; and
- at least one barrier layer comprised in and/or on the pixel defining layer.
2. The device according to claim 1, wherein the pixel defining layer has a thickness of about 1000 to 5000 Å.
3. The device according to claim 1, wherein the barrier layer has a thickness of about 10% or less of the thickness of the pixel defining layer.
4. The device according to claim 1, wherein the barrier layer is formed by curing an upper part of the pixel defining layer by injecting ions or inert gas onto the pixel defining layer.
5. The device according to claim 4, wherein the ions are ions of one element selected from a group consisting of B, P and As.
6. The device according to claim 4, wherein the inert gas is one selected from a group consisting of Ar, He, Xe, H<sub>2</sub>, and Ne.
7. The device according to claim 1, wherein edge portions of the barrier layers disposed in and/or on the pixel defining layer contact each other.
8. An electro luminescent (EL) display device comprising:
- a substrate;
  - a plurality of pixel electrodes disposed on the substrate;
  - a plurality of pixel defining layers disposed on the pixel electrodes and having an opening part exposing a part of each of the pixel electrodes; and
  - at least one barrier layer comprised in and/or on each of the pixel defining layers.
9. The device according to claim 8, wherein each of the pixel defining layers has a thickness of about 1000 to 5000 Å.
10. The device according to claim 8, wherein each of the barrier layers has a thickness of about 10% or less of the thickness of each of the pixel defining layers.
11. The device according to claim 8, wherein the barrier layer is formed by curing an upper part of each of the pixel defining layers by injecting ions or inert gas onto the pixel defining layers.
12. The device according to claim 11, wherein the ions are ions of one element selected from a group consisting of B, P and As.
13. The device according to claim 11, wherein the inert gas is one selected from a group consisting of Ar, He, Xe, H<sub>2</sub>, and Ne.
14. The device according to claim 8, wherein edge portions of the barrier layers disposed in and/or on each of the pixel defining layer contact each other.
15. A method of fabricating an electroluminescent (EL) display device, comprising:
- forming a pixel electrode on a substrate;
  - forming a pixel defining layer on the entire surface of the substrate having the pixel electrode, the pixel defining layer having an opening part exposing a part of the pixel electrode;
  - forming a barrier layer by injection impurities onto the pixel defining layer;
  - forming an emission layer on the exposed part of the pixel electrode; and
  - forming an opposing electrode on the organic layer.
16. The method according to claim 15, wherein the impurities are ions or inert gases.
17. The method according to claim 16, wherein the ions are ions of one element selected from a group consisting of B, P and As.
18. The method according to claim 16, wherein the ions are injected onto the pixel defining layer to a dose amount of about 10<sup>14</sup> to 10<sup>15</sup> ions/cm<sup>2</sup> at an acceleration energy of about 75 to about 85 keV.
19. The method according to claim 16, wherein the inert gas is one selected from a group consisting of Ar, He, Xe, H<sub>2</sub>, and Ne.
20. The method according to claim 16, wherein the inert gas is accelerated onto the pixel defining layer at a flow rate of at least 50 sccm at an electric power of about 100 W in a vacuum of about 10 to 400 mtorr.
21. The method according to claim 15, wherein the barrier layer is formed to a thickness that is equal to about 10% or less of the thickness of the pixel defining layer.
22. The method according to claim 15, further comprising: after forming the barrier layer on the pixel defining layer and before forming the organic layer on the exposed part of the pixel electrode,
- repeating at least once steps of forming a pixel defining layer on the entire surface of the substrate having the pixel electrode, the pixel defining layer having an opening part exposing a part of the pixel electrode;
  - forming a barrier layer by injection impurities into the pixel defining layer;
23. The method according to claim 22, wherein the barrier layers space apart from each other at predetermined intervals.
24. The method according to claim 22, wherein the barrier layers are formed to contact each other at edge portions of the barrier layers.
25. A method of fabricating an electroluminescent (EL) display device, comprising:
- forming a pixel electrode on a substrate;
  - forming a pixel defining layer on the entire surface of the substrate having the pixel electrode, the pixel defining layer having an opening part exposing a part of the pixel electrode;
  - forming a barrier layer by heat curing a part of the pixel defining layer
  - forming an emission layer on the exposed part of the pixel electrode; and
  - forming an opposing electrode on the organic layer.
26. The method according to claim 25, wherein forming the barrier layer on the pixel defining layer comprises forming the barrier layer by heat curing the pixel defining layer until the pixel defining layer shrinks to about 50% of an original thickness of the pixel defining layer.

**27.** The method according to claim 25, further comprising: after forming the barrier layer on the pixel defining layer and before forming the organic layer on the exposed part of the pixel electrode,

repeating at least once steps of forming a pixel defining layer on the entire surface of the substrate having the pixel electrode, the pixel defining layer having an opening part exposing a part of the pixel electrode;

forming a barrier layer by heat curing a part of the pixel defining layer.

**28.** The method according to claim 27, wherein each of the pixel defining layers is formed to a thickness of about 2000 Å.

**29.** The method according to claim 27, wherein the barrier layers space apart from each other at predetermined intervals.

**30.** The method according to claim 21, wherein the barrier layers are formed to contact each other at edge portions of the barrier layers.

\* \* \* \* \*

专利名称(译)	电致发光显示装置及其制造方法		
公开(公告)号	<a href="#">US20060022587A1</a>	公开(公告)日	2006-02-02
申请号	US11/143952	申请日	2005-06-03
[标]申请(专利权)人(译)	JEONG常勇 姜泰旭 金昌洙 CHO余崇		
申请(专利权)人(译)	JEONG长永 KANG TAE旭 金昌洙 CHO YU-SUNG		
当前申请(专利权)人(译)	三星DISPLAY CO. , LTD.		
[标]发明人	JEONG CHANG YONG KANG TAE WOOK KIM CHANG SOO CHO YU SUNG		
发明人	JEONG, CHANG-YONG KANG, TAE-WOOK KIM, CHANG-SOO CHO, YU-SUNG		
IPC分类号	H05B33/00 H05B33/22 H01L27/32 H01L51/50 H05B33/10 H05B33/12 H05B33/14		
CPC分类号	H01L27/3246 H01L51/5237 H01L27/3283 H01L51/5256		
优先权	1020040041066 2004-06-04 KR 1020040049709 2004-06-29 KR		
其他公开文献	US8278818		
外部链接	<a href="#">Espacenet</a> <a href="#">USPTO</a>		

摘要(译)

提供了一种电致发光 ( EL ) 显示装置及其制造方法。该装置包括基板;多个像素电极设置在基板上;像素限定层, 设置在像素电极上, 并具有暴露每个像素电极的预定部分的开口部分;至少一个阻挡层包含在像素限定层中和/或上。在该器件中, 像素限定层包括至少一个阻挡层, 以减少来自像素限定层的排气量, 并防止由于排气引起的发射部分的劣化。而且, 像素限定层形成为足够小的厚度, 以便于使用激光诱导热成像 ( LITI ) 工艺的后续工艺。

